

# ***Motion Control***

---

**National Instruments Universal  
Motion Interface (UMI)-7774/7772  
User Manual**

## **Worldwide Technical Support and Product Information**

ni.com

### **National Instruments Corporate Headquarters**

11500 North Mopac Expressway Austin, Texas 78759-3504 USA Tel: 512 683 0100

### **Worldwide Offices**

Australia 1800 300 800, Austria 43 0 662 45 79 90 0, Belgium 32 0 2 757 00 20, Brazil 55 11 3262 3599,  
Canada (Calgary) 403 274 9391, Canada (Montreal) 514 288 5722, Canada (Ottawa) 613 233 5949,  
Canada (Québec) 514 694 8521, Canada (Toronto) 905 785 0085, Canada (Vancouver) 514 685 7530,  
China 86 21 6555 7838, Czech Republic 420 2 2423 5774, Denmark 45 45 76 26 00,  
Finland 385 0 9 725 725 11, France 33 0 1 48 14 24 24, Germany 49 0 89 741 31 30, Greece 30 2 10 42 96 427,  
India 91 80 51190000, Israel 972 0 3 6393737, Italy 39 02 413091, Japan 81 3 5472 2970,  
Korea 82 02 3451 3400, Malaysia 603 9131 0918, Mexico 001 800 010 0793, Netherlands 31 0 348 433 466,  
New Zealand 0800 553 322, Norway 47 0 66 90 76 60, Poland 48 0 22 3390 150, Portugal 351 210 311 210,  
Russia 7 095 783 68 51, Singapore 65 6226 5886, Slovenia 386 3 425 4200, South Africa 27 0 11 805 8197,  
Spain 34 91 640 0085, Sweden 46 0 8 587 895 00, Switzerland 41 56 200 51 51, Taiwan 886 2 2528 7227,  
Thailand 662 992 7519, United Kingdom 44 0 1635 523545

For further support information, refer to the *Technical Support and Professional Services* appendix. To comment on the documentation, send email to [techpubs@ni.com](mailto:techpubs@ni.com).

© 2003 National Instruments Corporation. All rights reserved.

# Important Information

---

## Warranty

The NI UMI-7774/7772 is warranted against defects in materials and workmanship for a period of one year from the date of shipment, as evidenced by receipts or other documentation. National Instruments will, at its option, repair or replace equipment that proves to be defective during the warranty period. This warranty includes parts and labor.

The media on which you receive National Instruments software are warranted not to fail to execute programming instructions, due to defects in materials and workmanship, for a period of 90 days from date of shipment, as evidenced by receipts or other documentation. National Instruments will, at its option, repair or replace software media that do not execute programming instructions if National Instruments receives notice of such defects during the warranty period. National Instruments does not warrant that the operation of the software shall be uninterrupted or error free.

A Return Material Authorization (RMA) number must be obtained from the factory and clearly marked on the outside of the package before any equipment will be accepted for warranty work. National Instruments will pay the shipping costs of returning to the owner parts which are covered by warranty.

National Instruments believes that the information in this document is accurate. The document has been carefully reviewed for technical accuracy. In the event that technical or typographical errors exist, National Instruments reserves the right to make changes to subsequent editions of this document without prior notice to holders of this edition. The reader should consult National Instruments if errors are suspected. In no event shall National Instruments be liable for any damages arising out of or related to this document or the information contained in it.

EXCEPT AS SPECIFIED HEREIN, NATIONAL INSTRUMENTS MAKES NO WARRANTIES, EXPRESS OR IMPLIED, AND SPECIFICALLY DISCLAIMS ANY WARRANTY OF MERCHANTABILITY OR FITNESS FOR A PARTICULAR PURPOSE. CUSTOMER'S RIGHT TO RECOVER DAMAGES CAUSED BY FAULT OR NEGLIGENCE ON THE PART OF NATIONAL INSTRUMENTS SHALL BE LIMITED TO THE AMOUNT THEREOF PAID BY THE CUSTOMER. NATIONAL INSTRUMENTS WILL NOT BE LIABLE FOR DAMAGES RESULTING FROM LOSS OF DATA, PROFITS, USE OF PRODUCTS, OR INCIDENTAL OR CONSEQUENTIAL DAMAGES, EVEN IF ADVISED OF THE POSSIBILITY THEREOF. This limitation of the liability of National Instruments will apply regardless of the form of action, whether in contract or tort, including negligence. Any action against National Instruments must be brought within one year after the cause of action accrues. National Instruments shall not be liable for any delay in performance due to causes beyond its reasonable control. The warranty provided herein does not cover damages, defects, malfunctions, or service failures caused by owner's failure to follow the National Instruments installation, operation, or maintenance instructions; owner's modification of the product; owner's abuse, misuse, or negligent acts; and power failure or surges, fire, flood, accident, actions of third parties, or other events outside reasonable control.

## Copyright

Under the copyright laws, this publication may not be reproduced or transmitted in any form, electronic or mechanical, including photocopying, recording, storing in an information retrieval system, or translating, in whole or in part, without the prior written consent of National Instruments Corporation.

## Trademarks

National Instruments™, NI™, ni.com™, and NI-Motion™ are trademarks of National Instruments Corporation.

Product and company names mentioned herein are trademarks or trade names of their respective companies.

## Patents

For patents covering National Instruments products, refer to the appropriate location: **Help»Patents** in your software, the `patents.txt` file on your CD, or `ni.com/patents`.

## WARNING REGARDING USE OF NATIONAL INSTRUMENTS PRODUCTS

(1) NATIONAL INSTRUMENTS PRODUCTS ARE NOT DESIGNED WITH COMPONENTS AND TESTING FOR A LEVEL OF RELIABILITY SUITABLE FOR USE IN OR IN CONNECTION WITH SURGICAL IMPLANTS OR AS CRITICAL COMPONENTS IN ANY LIFE SUPPORT SYSTEMS WHOSE FAILURE TO PERFORM CAN REASONABLY BE EXPECTED TO CAUSE SIGNIFICANT INJURY TO A HUMAN.

(2) IN ANY APPLICATION, INCLUDING THE ABOVE, RELIABILITY OF OPERATION OF THE SOFTWARE PRODUCTS CAN BE IMPAIRED BY ADVERSE FACTORS, INCLUDING BUT NOT LIMITED TO FLUCTUATIONS IN ELECTRICAL POWER SUPPLY, COMPUTER HARDWARE MALFUNCTIONS, COMPUTER OPERATING SYSTEM SOFTWARE FITNESS, FITNESS OF COMPILERS AND DEVELOPMENT SOFTWARE USED TO DEVELOP AN APPLICATION, INSTALLATION ERRORS, SOFTWARE AND HARDWARE COMPATIBILITY PROBLEMS, MALFUNCTIONS OR FAILURES OF ELECTRONIC MONITORING OR CONTROL DEVICES, TRANSIENT FAILURES OF ELECTRONIC SYSTEMS (HARDWARE AND/OR SOFTWARE), UNANTICIPATED USES OR MISUSES, OR ERRORS ON THE PART OF THE USER OR APPLICATIONS DESIGNER (ADVERSE FACTORS SUCH AS THESE ARE HEREAFTER COLLECTIVELY TERMED "SYSTEM FAILURES"). ANY APPLICATION WHERE A SYSTEM FAILURE WOULD CREATE A RISK OF HARM TO PROPERTY OR PERSONS (INCLUDING THE RISK OF BODILY INJURY AND DEATH) SHOULD NOT BE RELIANT SOLELY UPON ONE FORM OF ELECTRONIC SYSTEM DUE TO THE RISK OF SYSTEM FAILURE. TO AVOID DAMAGE, INJURY, OR DEATH, THE USER OR APPLICATION DESIGNER MUST TAKE REASONABLY PRUDENT STEPS TO PROTECT AGAINST SYSTEM FAILURES, INCLUDING BUT NOT LIMITED TO BACK-UP OR SHUT DOWN MECHANISMS. BECAUSE EACH END-USER SYSTEM IS CUSTOMIZED AND DIFFERS FROM NATIONAL INSTRUMENTS' TESTING PLATFORMS AND BECAUSE A USER OR APPLICATION DESIGNER MAY USE NATIONAL INSTRUMENTS PRODUCTS IN COMBINATION WITH OTHER PRODUCTS IN A MANNER NOT EVALUATED OR CONTEMPLATED BY NATIONAL INSTRUMENTS, THE USER OR APPLICATION DESIGNER IS ULTIMATELY RESPONSIBLE FOR VERIFYING AND VALIDATING THE SUITABILITY OF NATIONAL INSTRUMENTS PRODUCTS WHENEVER NATIONAL INSTRUMENTS PRODUCTS ARE INCORPORATED IN A SYSTEM OR APPLICATION, INCLUDING, WITHOUT LIMITATION, THE APPROPRIATE DESIGN, PROCESS AND SAFETY LEVEL OF SUCH SYSTEM OR APPLICATION.

# Compliance

---

## FCC/Canada Radio Frequency Interference Compliance

### Determining FCC Class

The Federal Communications Commission (FCC) has rules to protect wireless communications from interference. The FCC places digital electronics into two classes. These classes are known as Class A (for use in industrial-commercial locations only) or Class B (for use in residential or commercial locations). All National Instruments (NI) products are FCC Class A products.

Depending on where it is operated, this Class A product could be subject to restrictions in the FCC rules. (In Canada, the Department of Communications (DOC), of Industry Canada, regulates wireless interference in much the same way.) Digital electronics emit weak signals during normal operation that can affect radio, television, or other wireless products.

All Class A products display a simple warning statement of one paragraph in length regarding interference and undesired operation. The FCC rules have restrictions regarding the locations where FCC Class A products can be operated.

Consult the FCC Web site at [www.fcc.gov](http://www.fcc.gov) for more information.

### FCC/DOC Warnings

This equipment generates and uses radio frequency energy and, if not installed and used in strict accordance with the instructions in this manual and the CE marking Declaration of Conformity\*, may cause interference to radio and television reception. Classification requirements are the same for the Federal Communications Commission (FCC) and the Canadian Department of Communications (DOC).

Changes or modifications not expressly approved by NI could void the user's authority to operate the equipment under the FCC Rules.

## Class A

### Federal Communications Commission

This equipment has been tested and found to comply with the limits for a Class A digital device, pursuant to part 15 of the FCC Rules. These limits are designed to provide reasonable protection against harmful interference when the equipment is operated in a commercial environment. This equipment generates, uses, and can radiate radio frequency energy and, if not installed and used in accordance with the instruction manual, may cause harmful interference to radio communications. Operation of this equipment in a residential area is likely to cause harmful interference in which case the user is required to correct the interference at their own expense.

### Canadian Department of Communications

This Class A digital apparatus meets all requirements of the Canadian Interference-Causing Equipment Regulations.

Cet appareil numérique de la classe A respecte toutes les exigences du Règlement sur le matériel brouilleur du Canada.

### Compliance to EU Directives

Readers in the European Union (EU) must refer to the manufacturer's Declaration of Conformity (DoC) for information\* pertaining to the CE marking compliance scheme. The manufacturer includes a DoC for most hardware products except for those bought from OEMs. In addition, DoCs are usually not provided if compliance is not required, for example electrically benign apparatus or cables.

To obtain the DoC for this product, click **Declarations of Conformity Information** at [ni.com/hardref.nsf/](http://ni.com/hardref.nsf/). This Web site lists the DoCs by product family. Select the appropriate product family, followed by your product, and a link to the DoC appears in Adobe Acrobat format. Click the Acrobat icon to download or read the DoC.

\* The CE marking Declaration of Conformity contains important supplementary information and instructions for the user or installer.

# Contents

---

## About This Manual

Conventions .....	vii
Related Documentation.....	vii

## Chapter 1 Introduction

About the UMI-7774/7772 .....	1-1
Features.....	1-2

## Chapter 2 Installation

Required Materials.....	2-1
Optional Equipment.....	2-2
Before Getting Started .....	2-2
Noise Considerations.....	2-2
Safety Information.....	2-3
Unpacking the UMI-7774/7772 .....	2-5
Installation .....	2-5
Mounting the UMI-7774/7772.....	2-6
Mounting the UMI-7774/7772 on a DIN Rail.....	2-7
Mounting the UMI-7774/7772 on a Panel.....	2-8
Mounting the UMI-7774/7772 in a Standard 19-in. Rack .....	2-11

## Chapter 3 Connecting the UMI-7774/7772 to Drives and Other Devices

Connecting the UMI-7774/7772 to National Instruments Motion Controllers .....	3-2
Connecting the UMI-7774/7772 to Optional General-Purpose Digital I/O Devices.....	3-2
Voltage Considerations for the UMI-7774/7772 .....	3-3
Power Requirements .....	3-3
Connector Descriptions.....	3-5
Power Input Terminal Block .....	3-5
Power Status Indicators .....	3-5
Control Connector for Each Axis .....	3-5
Analog Output.....	3-7
Step (CW) and Dir (CCW).....	3-7
Fault .....	3-8
Enable Output .....	3-10

Fault Input and Disabled Status Indicators .....	3-12
Sinusoidal Commutation Configuration .....	3-12
Feedback Connector for Each Axis .....	3-15
Encoder .....	3-17
Limit and Home Inputs .....	3-19
Limit and Home Status Indicators .....	3-21
Hall Effect Sensors for Sinusoidal Commutation Configuration .....	3-22
Global Stop .....	3-23
Inhibit All .....	3-23
Shutdown .....	3-24
Analog Input .....	3-24
Trigger/Breakpoint .....	3-25
Trigger .....	3-25
Breakpoint .....	3-26
General-Purpose Digital I/O .....	3-27
Connecting Switches to UMI-7774/7772 Sinking Inputs .....	3-29
Inductive Loads Connected to UMI-7774/7772 .....	3-30
Servo Drive Modes .....	3-31
National Instruments Motion Advisors .....	3-31

## **Appendix A**

### **Specifications**

## **Appendix B**

### **Technical Support and Professional Services**

## **Index**

# About This Manual

---

The *National Instruments Universal Motion Interface (UMI)-7774/7772 User Manual* provides information about the UMI-7774/7772 functionality and includes instructions for getting started, specifications, connection requirements, and safety information.

## Conventions

---

The following conventions appear in this manual:

»

The » symbol leads you through nested menu items and dialog box options to a final action. The sequence **File»Page Setup»Options** directs you to pull down the **File** menu, select the **Page Setup** item, and select **Options** from the last dialog box.



This icon denotes a note, which alerts you to important information.



This icon denotes a caution, which advises you of precautions to take to avoid injury, data loss, or a system crash.

**bold**

Bold text denotes items that you must select or click in the software, such as menu items and dialog box options. Bold text also denotes parameter names.

*italic*

Italic text denotes variables, emphasis, a cross reference, or an introduction to a key concept. This font also denotes text that is a placeholder for a word or value that you must supply.

monospace

Text in this font denotes text or characters that you should enter from the keyboard, sections of code, programming examples, and syntax examples. This font is also used for the proper names of disk drives, paths, directories, programs, subprograms, subroutines, device names, functions, operations, variables, filenames and extensions, and code excerpts.

## Related Documentation

---

The following documents contain information that you might find helpful as you read this manual:

- National Instruments motion controller documentation
- *Measurement & Automation Explorer for Motion* help

---

# Introduction

This manual provides information about the National Instruments Universal Motion Interface (UMI)-7774/7772 functionality and includes instructions for getting started, specifications, connection requirements, and safety information.

## About the UMI-7774/7772

---

The UMI-7774 and UMI-7772 (UMI-7774/7772) are standalone connectivity accessories designed to be used with National Instruments 73xx series motion controllers for up to four axes of simultaneous or independent control. Ideally suited to industrial and laboratory applications, the UMI-7774/7772 connects third-party stepper and servo drives (amplifiers) and/or feedback and digital I/O to National Instruments motion controllers.

The UMI-7772 is a two-axis version of the UMI-7774. All illustrations, information, and specifications in this manual apply to both devices.



**Note** For consistency, the remainder of this user manual refers only to drives. All references to drives also apply to amplifiers.

You can use the UMI-7774/7772 with a wide variety of drives designed for many types of motor or actuator types and power ranges. This flexibility allows you to use the UMI-7774/7772 in systems where you must use a third-party drive.

To work correctly with the UMI-7774/7772, the drives must have industry standard interfaces. For stepper systems, the industry standard interface includes step and direction, or CW (clockwise) and CCW (counter-clockwise), pulse inputs. For servo systems, the industry standard interface includes  $\pm 10$  V analog input.



## Features

The UMI-7774/7772 is designed for use with the National Instruments 73xx series motion controllers. This section provides an overview of the UMI-7774/7772 functionality.

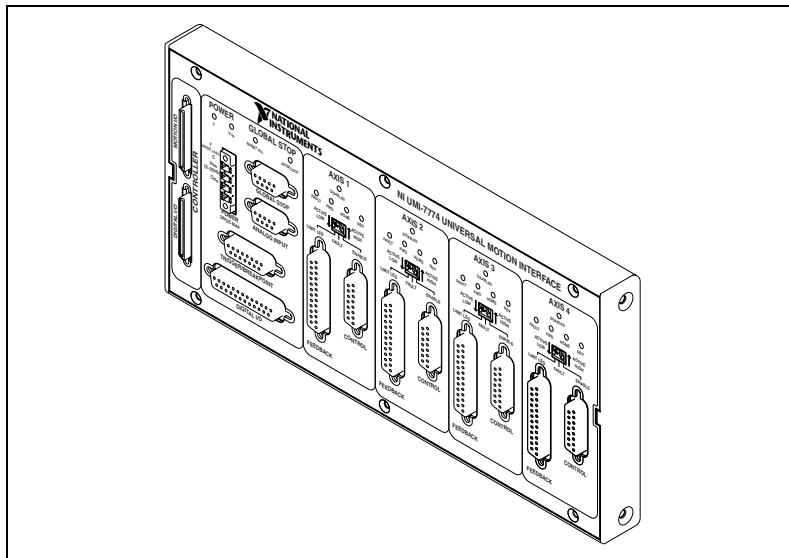

**Figure 1-1.** UMI-7774

The UMI-7774/7772 simplifies field wiring by supplying a separate feedback and control D-Sub connector for each axis. The UMI-7774/7772 connects the motion input and output to the motion controller by a single interface cable. You can connect the UMI-7774/7772 digital inputs and outputs to the controller with a separate interface cable to provide access to up to eight digital inputs and eight digital outputs on the controller. Also, the UMI-7774/7772 features a host bus monitor power interlock that automatically disables the drive if the host computer is shut down or the motion input/output interface cable is disconnected.

The UMI-7774/7772 includes the following features:

- D-Sub connectivity, which provides easy and durable connectivity to third-party devices.
- 5 to 30 V limits and home switch/sensor compatibility.
- Global Stop inputs for global shutdown of all axes.

- Optical isolation on inhibit signals, global stop inputs, triggers, limits, home and digital I/O. This feature enables 24 VDC signaling capability. Also, the isolation can help break ground loops in the system and reduce the effects of noise and voltage transients.
- Global and per-axis status LEDs.
- Capability to interface with low-cost third-party brushless motor drives that do not provide sinusoidal commutation.
- Access to eight digital inputs and eight digital outputs.
- Panel, DIN rail, or rack mountable.

---

# Installation

This chapter describes the necessary and optional items for getting started with the UMI-7774/7772. This chapter also explains how to unpack, configure, and install the UMI-7774/7772.

## Required Materials

---

The following items are necessary for installing and getting started with the UMI-7774/7772:

- UMI-7774 or UMI-7772
- This manual
- 24  $\pm$ 10% VDC power supply (10 W minimum)
- 5 to 30 V isolated power supply (10 to 60 W minimum depending on I/O requirements)
- A National Instruments 73.xx series motion controller
- National Instruments motion controller documentation
- One of the following National Instruments SHC68-C68-S cables for connecting a motion controller to the UMI-7774/7772:
  - 2 m (part number 186380-02)
  - 0.5 m (part number 186380-0R5)
- Custom cable for connecting the UMI-7774/7772 to a third-party drive
- Third-party drive and documentation



**Note** For a current list of the third-party drives that the UMI-7774/7772 supports, visit the National Instruments Motion Control Web site at [ni.com/motion](http://ni.com/motion).

## Optional Equipment

National Instruments offers a variety of products for use with the UMI-7774/7772, including the following:

- Mounting accessories. Refer to the [Mounting the UMI-7774/7772](#) section for information about specific equipment for each available mounting package.
- Separate +24 V power supply for isolated I/O.
- Additional SH-68-C68-S Cable (0.5 or 2 m) with 68-pin VHDCI offset male connectors on both ends. Use this cable to connect the digital I/O connector on the National Instruments motion controller to the digital I/O connector on the UMI-7774/7772.

## Before Getting Started

---

This section provides information about noise considerations and safety guidelines as well as instructions for unpacking the UMI-7774/7772.

### Noise Considerations

Before connecting the UMI-7774/7772, verify that all system components are grounded correctly and that all wiring is properly shielded. Do not connect high-voltage wires and low-level signals to the same channel.

The following list includes additional noise considerations.

- Keep high voltage lines, such as AC power cables and motor drive cables, away from low-level signals, such as encoders and limits.
- Use twisted pair cable for differential signals, such as encoders.
- Ensure that all cables connected to the UMI-7774/7772 include a braided shield.
- Use hoods with internal metallic shielding for D-Sub connectors.
- Ensure that all devices in the system, including the UMI-7774/7772, drives, and motors, are properly grounded.
- Ensure that all power supplies and motor drives in the system are powered down when connecting them to the UMI-7774/7772.



**Caution** Failure to follow these precautions may result in system instability and may cause permanent damage to system components.

## Safety Information



**Caution** The following paragraphs contain important safety information you *must* follow when installing and operating the UMI-7774/7772 and all devices connecting to the UMI-7774/7772.

Do *not* operate the device in a manner not specified in the documentation. Misuse of the device may result in a hazard and may compromise the safety protection built into the device. If the device is damaged, turn it off and do *not* use it until service-trained personnel can check its safety. If necessary, return the device to National Instruments for repair.

Keep away from live circuits. Do *not* remove equipment covers or shields unless you are trained to do so. If signal wires are connected to the device, hazardous voltages can exist even when the equipment is turned off. To avoid a shock hazard, do *not* perform procedures involving cover or shield removal unless you are qualified to do so. Disconnect all field power prior to removing covers or shields.

If the device is rated for use with hazardous voltages ( $>30 V_{\text{rms}}$ ,  $42.4 V_{\text{pk}}$ , or  $60 V_{\text{dc}}$ ), it may require a safety earth-ground connection wire. Refer to the device specifications for maximum voltage ratings.



**Note** Although some signal lines on the UMI-7774/7772 have optical isolation to reduce noise effects and ground loops, the UMI-7774/7772 does not include safety isolation features. Also, there is no isolation between signals, connectors, or axes on the UMI-7774/7772 unless otherwise noted.

Because of the danger of introducing additional hazards, do *not* install unauthorized parts or modify the device. Use the device only with the chassis, modules, accessories, and cables specified in the installation instructions. All covers and filler panels must be installed while operating the device.

Do *not* operate the device in an explosive atmosphere or where flammable gases or fumes may be present. Operate the device only at or below the pollution degree stated in the specifications. Pollution consists of any

foreign matter—solid, liquid, or gas—that may reduce dielectric strength or surface resistivity. Pollution degrees are listed below.

- Pollution Degree 1—No pollution or only dry, nonconductive pollution occurs. The pollution has no effect.
- Pollution Degree 2—Normally only nonconductive pollution occurs. Occasionally, nonconductive pollution becomes conductive because of condensation.
- Pollution Degree 3—Conductive pollution or dry, nonconductive pollution occurs. Nonconductive pollution becomes conductive because of condensation.

Clean the device and accessories by brushing off light dust with a soft, nonmetallic brush. Remove other contaminants with a stiff, nonmetallic brush. The unit *must* be completely dry and free from contaminants before returning it to service.

You *must* insulate signal connections for the maximum voltage for which the device is rated. Do *not* exceed the maximum ratings for the device. Remove power from signal lines before connection to or disconnection from the device.



**Caution** National Instruments measurement products may be classified as either Installation Category I or II. Operate products at or below the Installation Category level specified in the hardware specifications.

**Installation Category<sup>1</sup>:** Measurement circuits are subjected to working voltages<sup>2</sup> and transient stresses (overvoltage) from the circuit to which they are connected during measurement or test. Installation Category establishes standardized impulse withstand voltage levels that commonly occur in electrical distribution systems. The following is a description of Installation (Measurement<sup>3</sup>) Categories:

- Installation Category I is for measurements performed on circuits *not* directly connected to the electrical distribution system referred to as MAINS<sup>4</sup> voltage. This category is for measurements of voltages from specially protected secondary circuits. Such voltage measurements include signal levels, special equipment, limited-energy parts of

<sup>1</sup> Installation Categories as defined in electrical safety standard IEC 61010-1.

<sup>2</sup> Working voltage is the highest rms value of an AC or DC voltage that can occur across any particular insulation.

<sup>3</sup> Installation Category is also referred to as Measurement Category.

<sup>4</sup> MAINS is defined as the (hazardous live) electrical supply system to which equipment is designed to be connected for the purpose of powering the equipment. Suitably rated measuring circuits may be connected to the MAINS for measuring purposes.

equipment, circuits powered by regulated low-voltage sources, and electronics.

- Installation Category II is for measurements performed on circuits directly connected to the electrical distribution system. This category refers to local-level electrical distribution, such as that provided by a standard wall outlet (for example, 115 V for U.S. or 230 V for Europe). Examples of Installation Category II are measurements performed on household appliances, portable tools, and similar products.
- Installation Category III is for measurements performed in the building installation at the distribution level. This category refers to measurements on hard-wired equipment such as equipment in fixed installations, distribution boards, and circuit breakers. Other examples are wiring, including cables, bus-bars, junction boxes, switches, socket-outlets in the fixed installation, and stationary motors with permanent connections to fixed installations.
- Installation Category IV is for measurements performed at the primary electrical supply installation (<1,000 V). Examples include electricity meters and measurements on primary overcurrent protection devices and on ripple control units.

## Unpacking the UMI-7774/7772

The UMI-7774/7772 ships in an antistatic package to prevent electrostatic discharge from damaging board components.

After removing the UMI-7774/7772 from the package, inspect it for loose components or any other signs of damage. Contact National Instruments if the device appears damaged in any way.



**Caution** Do *not* touch exposed connector pins. Doing so may cause damage to the device.

## Installation

---

Complete following steps to install the UMI-7774/7772.

1. Mount the UMI-7774/7772, if necessary.
2. Connect it to third-party stepper and servo drives and/or feedback and digital I/O connectors on National Instruments motion controllers.
3. Test signal connections starting with limits and home switches, moving on to encoders, and then move on to inhibit and command.

# Mounting the UMI-7774/7772

You can mount the UMI-7774/7772 on a 35 mm DIN rail, on a panel, or in a standard 19 in. rack. The following sections include instructions for all three mounting methods. Before using any of these mounting methods, record the serial number from the back of the UMI-7774/7772. You will be unable to read the serial number after you have mounted the UMI-7774/7772.



**Caution** When you mount the UMI-7774/7772 and connect cables to it, allow 51–76 mm (2–3 in.) of space between each side of the device and any other surface to ensure appropriate air circulation.

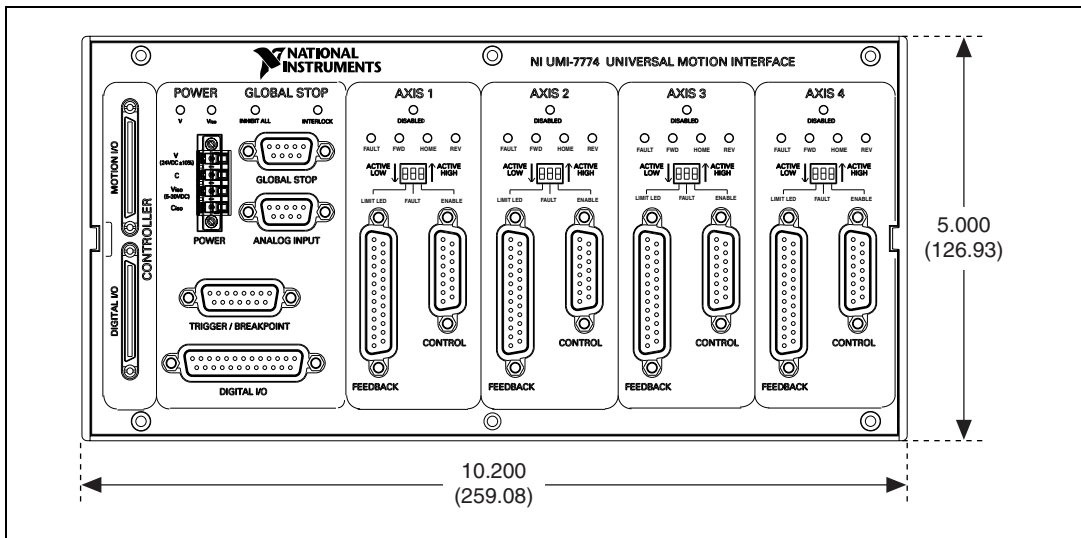

Figure 2-1. UMI-7774, Front View with Dimensions

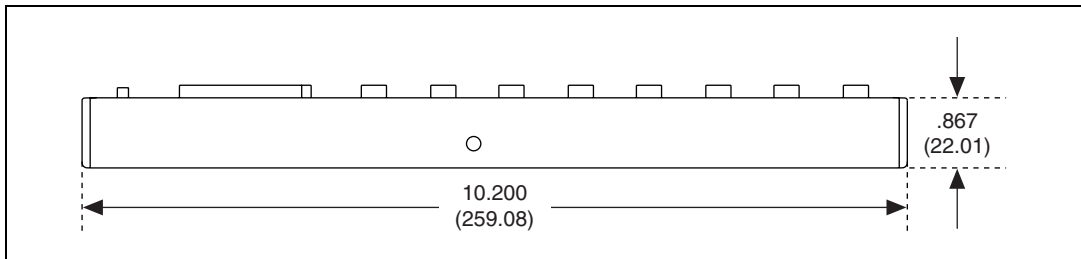

Figure 2-2. UMI-7774, Bottom View with Dimensions



## Mounting the UMI-7774/7772 on a DIN Rail

The UMI-7774/7772 has one clip for mounting on a standard 35 mm DIN rail. You can order the DIN rail mounting kit, part number 778710-01, from National Instruments. Complete the following steps to mount the UMI-7774/7772 on a DIN rail.

1. Refer to Figure 2-3. Fasten the DIN rail clip to the UMI-7774/7772 using a number 2 Phillips screwdriver and the two 8-32  $\times$  .25 in. countersink screws shipped with the DIN rail clip. These screws have a nylon coating to prevent them from loosening.

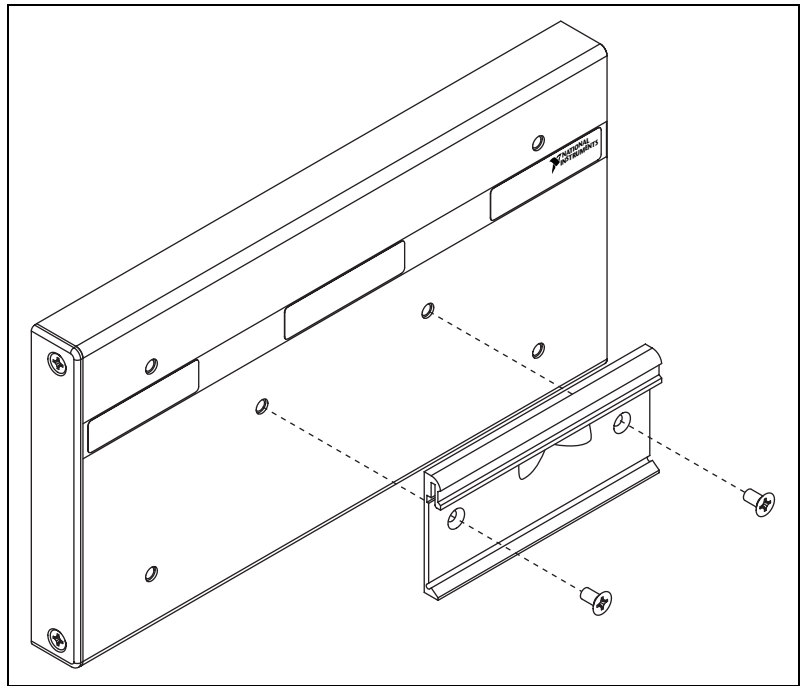
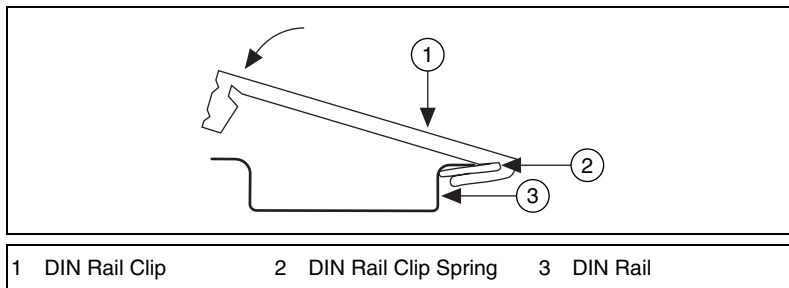

**Figure 2-3.** Fastening the DIN Rail Clip to the UMI-7774/7772



**Caution** To prevent damage to the UMI-7774/7772, do *not* use screws longer than .25 in. to fasten the DIN rail clip to the UMI-7774/7772.

2. Insert one edge of the DIN rail into the deeper opening of the DIN rail clip, as shown in Figure 2-4.
3. Press down firmly on the UMI-7774/7772 to compress the spring until the clip locks in place on the DIN rail.



**Figure 2-4.** One Edge of DIN Rail Inserted in Clip



**Caution** Disconnect power before removing the UMI-7774/7772 from the DIN rail.

## Mounting the UMI-7774/7772 on a Panel

To mount the UMI-7774/7772 on a panel, you need one of the optional panel-mount kits. You can order the appropriate kit, part number 778709-01 or 778711-01, from National Instruments.

Complete the following steps to install the panel-mount kit.

1. Fasten the two brackets of the panel-mount kit to the back of the UMI-7774/7772 using a number 2 Phillips screwdriver and the 8-32 × .25 in. countersink screws shipped with the kit. These screws have a nylon coating to prevent them from loosening. Refer to Figures 2-5, 2-6, 2-7, and 2-8 for illustrations of mounting the UMI-7774/7772 on a panel.

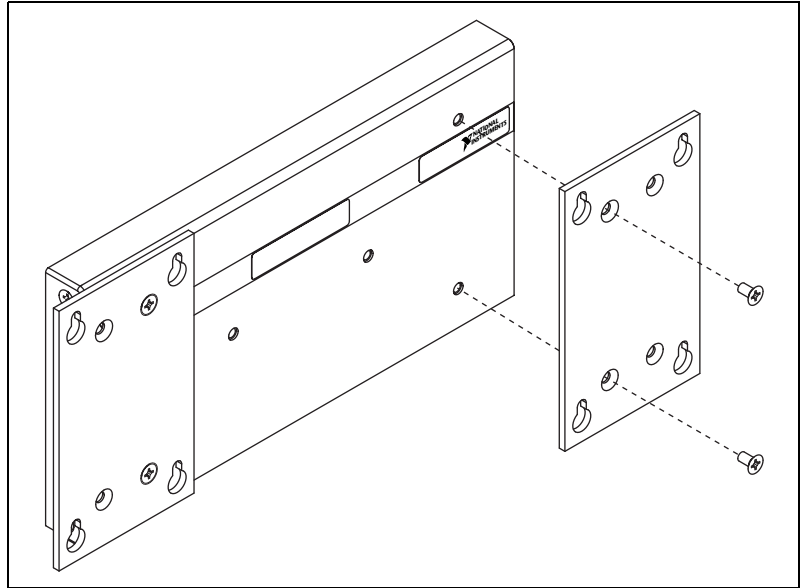

**Figure 2-5.** Fastening the Horizontal Panel-Mount Brackets to the UMI-7774/7772

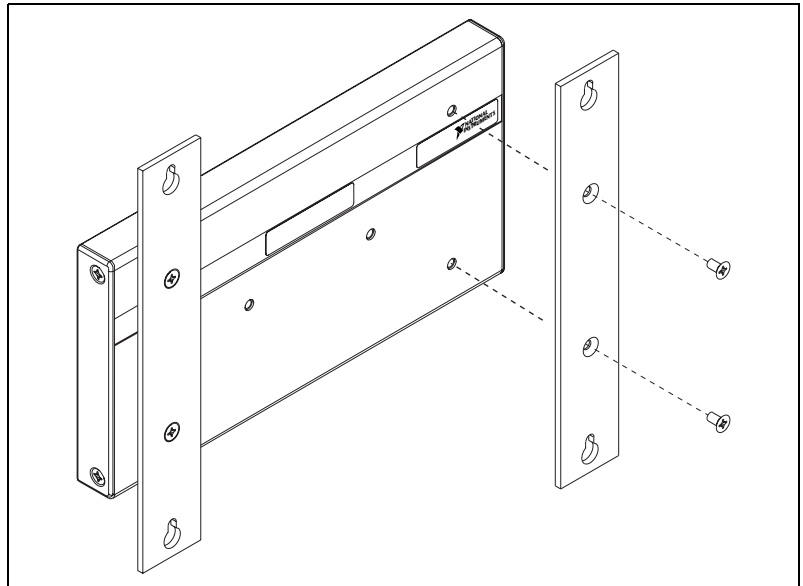

**Figure 2-6.** Fastening the Vertical Panel-Mount Brackets to the UMI-7774/7772



**Caution** Do not use screws longer than .25 in. to fasten the panel-mount accessory brackets to the UMI-7774/7772.

2. Attach the panel-mount accessory to a panel using 8-32 or M4 screws.

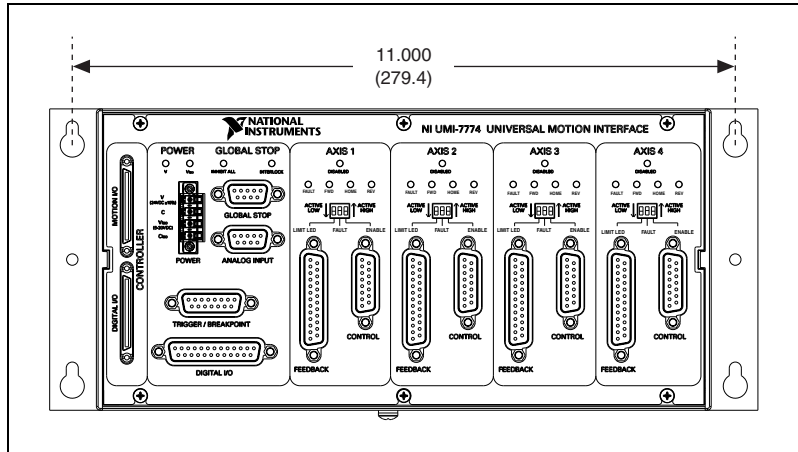

Figure 2-7. UMI-7774/7772 Front View with Horizontal Panel Mount Dimensions

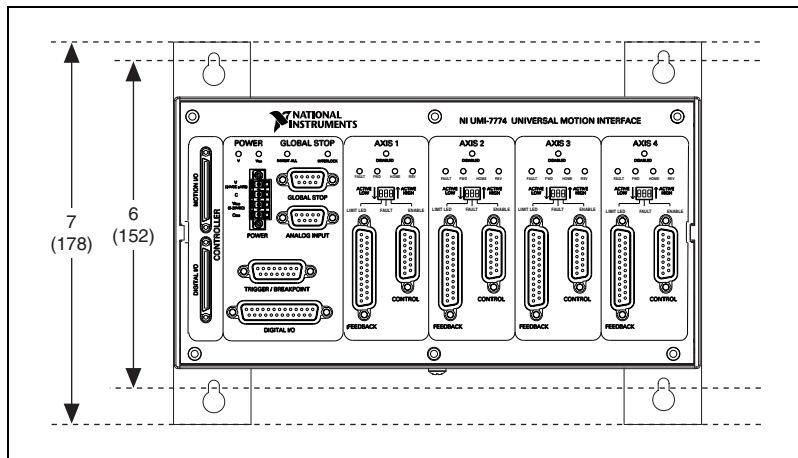

Figure 2-8. UMI-7774/7772 Front View with Vertical Panel Mount Dimensions



**Caution** Disconnect power before removing the UMI-7774/7772 from the panel.

## Mounting the UMI-7774/7772 in a Standard 19-in. Rack

To mount the UMI-7774/7772 in an EIA-standard 19-in. rack, you need the rack-mount kit. You can order the kit, part number 778712-01, from National Instruments.

Complete the following steps to install the rack-mount kit.

1. Fasten the rack-mount bracket to the back of the UMI-7774/7772 using the captive screws on the bracket.

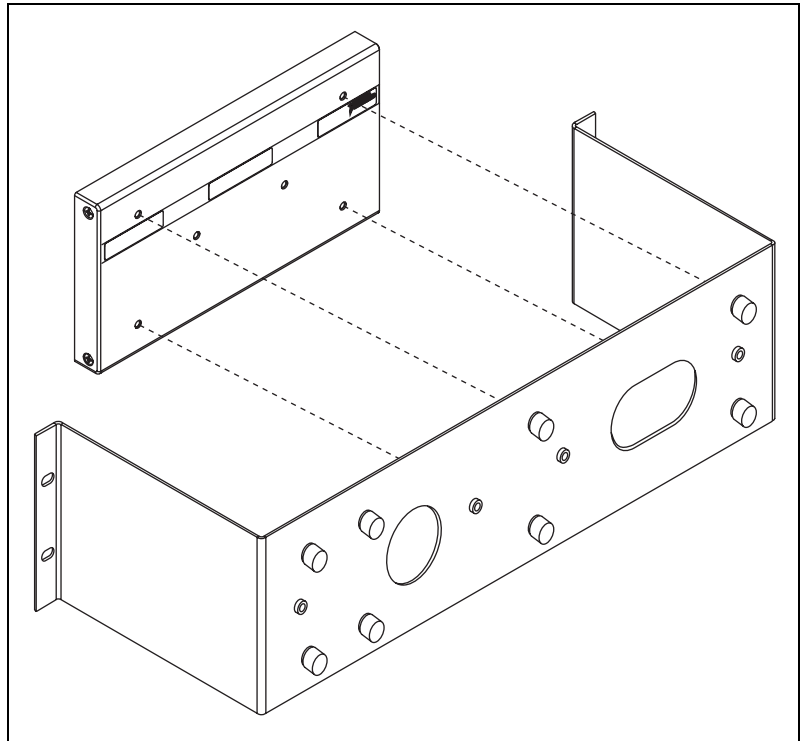

**Figure 2-9.** Fastening the Rack-Mount Accessory to the UMI-7774/7772

2. Bolt the rack-mount accessory to a standard 19 in. rack.



**Caution** Disconnect power before removing the UMI-7774/7772 from the rack.

# Connecting the UMI-7774/7772 to Drives and Other Devices

This chapter describes how to wire National Instruments motion controllers, third-party drives, sensors, and field I/O to the UMI-7774/7772. This chapter also describes the polarity settings and LED indicators on the UMI-7774/7772. Figure 3-1 shows the UMI-7774/7772.

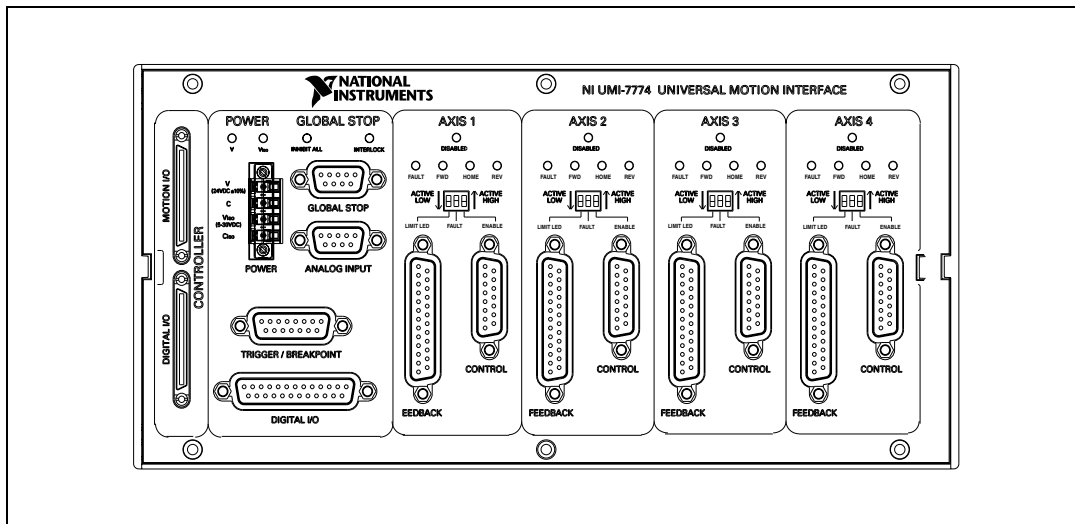

Figure 3-1. UMI-7774/7772 Front View

## Connecting the UMI-7774/7772 to National Instruments Motion Controllers

To connect the UMI-7774/7772 to a National Instruments motion controller, connect one end of the SHC68-C68-S cable to the 68-pin Motion I/O connector on the motion controller and the other end to the 68-pin Motion I/O connector on the UMI-7774/7772.

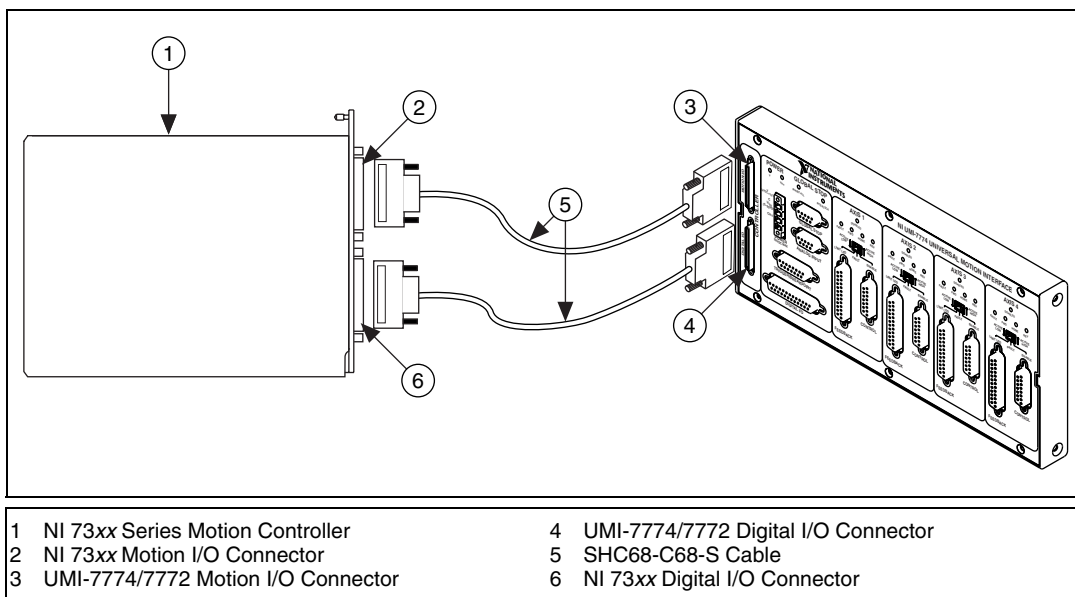

Figure 3-2. UMI-7774/7772 Connected to an NI 73xx Series Motion Controller

## Connecting the UMI-7774/7772 to Optional General-Purpose Digital I/O Devices

To access 16 (eight inputs and eight outputs) of the 32 digital I/O signals on the National Instruments motion controller, connect one end of an additional SHC68-C68-S cable to the 68-pin digital I/O connector on the motion controller and the other end to the 68-pin digital I/O connector on the UMI-7774/7772.

To access all of the 32 digital I/O signals on the motion controller, you can connect the digital I/O connector on the motion controller to other National Instruments accessories. For example, you can connect the digital I/O on the National Instruments motion controller to an SSR cable adapter and connect the adapter to the National Instruments SSR Series backplanes for use with other National Instruments devices, such as DAQ devices. Typically, you do not connect anything to the UMI-7774/7772 digital input/output connector in this case.

## Voltage Considerations for the UMI-7774/7772

---



**Caution** Do *not* connect the UMI-7774/7772 isolated power to a source greater than 30 V. Doing so may cause damage to UMI-7774/7772 components.

To cause current to flow through the input, the voltage applied to the following types of inputs should be greater than 3.5 V and less than 30 V.

- Fault inputs
- Limit and home inputs
- Global Stop inputs
- Trigger/breakpoint inputs
- General-purpose digital inputs

Also, the source must be able to provide at least 7.2 mA to turn on the *optical isolator* and result in an ON condition. When the applied voltage is below 2 V, the input results in an OFF condition.

Optical isolation is a method for transmitting a signal from its source to a measurement device without a physical connection by using an optical coupling technique. Optical isolation can help break ground loops in the system and reduce the effects of noise and voltage transients.

## Power Requirements

---

The UMI-7774/7772 includes a four-position power connector that provides voltage and common for the main power supply as well as voltage and common for the isolated output circuitry.



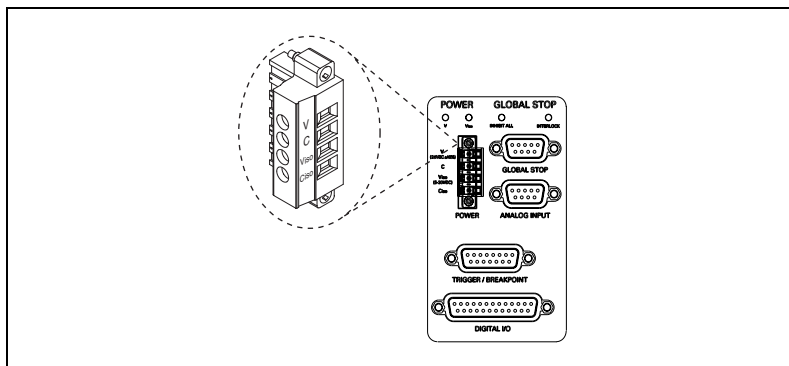

**Figure 3-3.** UMI-7774/7772 Power Input

Table 3-1 includes descriptions of each of the terminals on the UMI-7774/7772 power connector.

**Table 3-1.** Power Connector Terminals

Terminal	Description
V	Main power (24V ±10%)
C	Common
V <sub>iso</sub>	Isolated power (5 to 30 VDC)
C <sub>iso</sub>	Isolated common

Complete the following steps to wire power to the UMI-7774/7772.

1. Connect the positive lead of the 24 VDC power supply to the V terminal and the negative lead to the C terminal on the UMI-7774/7772.
2. If you use a separate power supply, connect the positive lead of the 5–30 VDC supply to the V<sub>iso</sub> terminal and the negative lead to the C<sub>iso</sub> terminal on the UMI-7774/7772.
3. If you do not use the isolation feature on the UMI-7774/7772, you must connect the V terminal to the V<sub>iso</sub> terminal and the C terminal to the C<sub>iso</sub> terminal.

These connections provide a source for the optically isolated output signals on the UMI-7774/7772, including the drive enable outputs and digital outputs. Also, these connections allow the optically isolated output signals to switch between 0 and 24 V.

# Connector Descriptions

---

The following sections include voltage considerations for the connectors on the UMI-7774/7772 as well as descriptions of the connectors and signals.

## Power Input Terminal Block

The UMI-7774/7772 requires a 24 VDC power supply to operate. The UMI-7774/7772 has a 4-position terminal block for wiring 24 VDC power and isolated power that is 5 to 30 VDC to the UMI-7774/7772. The isolated power is used in the optical isolation output circuitry for the drive enable outputs and digital output signals. Isolation can help break ground loops in the system and reduce the effects of noise and voltage transients.

$V_{iso}$  and  $C_{iso}$  are redistributed to other connectors on the UMI-7774/7772 as an output power source for external devices. Refer to Figure 3-1 to locate the power input terminal block on the UMI-7774/7772. Figure 3-4 shows the 4-position power connector and Table 3-1 shows the power connector terminal block pinout.



**Note** When the drive enable output and digital output signals are in an ON state, they provide isolated power. Use an isolated power supply with a voltage that is compatible with the inputs that the drive enable and digital outputs are connected to.  $V_{iso}$  and  $C_{iso}$  do *not* provide safety isolation.

## Power Status Indicators

When you finish making the required power connections to the  $V$ ,  $C$ ,  $V_{iso}$ , and  $C_{iso}$  terminals, power on the 24 VDC power supply. The  $V$  LED illuminates. If the 24 VDC power supply also has been connected to the  $V_{iso}$  and  $C_{iso}$  terminals, the  $V_{iso}$  LED illuminates. If you are using a separate power supply to provide isolation, power on the separate 5 to 30 V power supply and the  $V_{iso}$  LED indicator illuminates. Refer to Figure 3-1 for an illustration of the  $V$  and  $V_{iso}$  LEDs.

## Control Connector for Each Axis

Each axis connected to the UMI-7774/7772 has a 15-pin D-Sub control connector to which you wire drive command and drive enable signals. Figure 3-4 shows the pin locations of the control connector for each axis. Table 3-2 shows the corresponding signals for each pin.

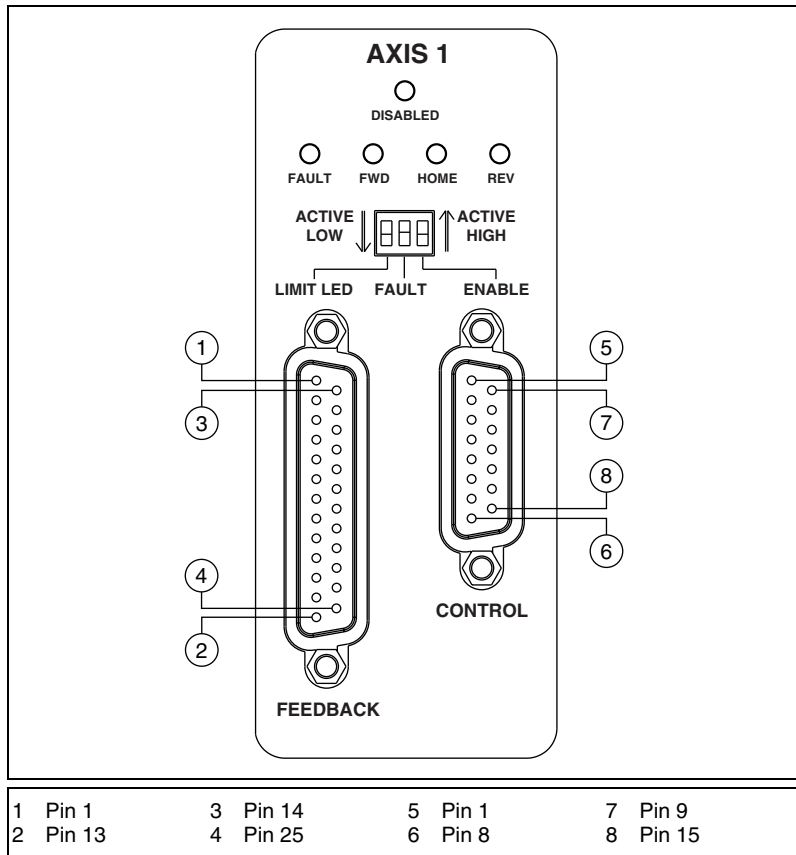

**Figure 3-4.** UMI-7774/7772 Per Axis Control and Feedback Connectors, LED Status Indicators, and Polarity Switches (Axis 1 Shown as Example)

**Table 3-2.** Per Axis Control Connector Pin Assignment

Pin	Signal	Optically Isolated
1	Analog Output	No
2	n.c.	No
3	+ 5 V (Output)	No
4	Step (CW)	No
5	n.c.	No
6	Enable	Yes

**Table 3-2.** Per Axis Control Connector Pin Assignment (Continued)

Pin	Signal	Optically Isolated
7	Fault +	Yes
8	Iso Power (Output)	Yes
9	Analog Output Ground	No
10	Digital Ground	No
11	Digital Ground	No
12	Dir (CCW)	No
13	n.c.	No
14	Fault –	Yes
15	Iso Common	Yes

## Analog Output

The UMI-7774/7772 analog output signals are used as command outputs to servo drives or as general-purpose voltage outputs. To help keep digital noise separate from the analog outputs, Pin 9 provides a separate analog output ground connection. Use this analog ground connection instead of a digital ground when you connect the UMI-7774/7772 to servo drives. Analog outputs are *pass-through signals* from the motion controller. A pass-through signal provides passive filtering on the signals, which does not affect the voltage range or current-handling capability of the signals.

## Step (CW) and Dir (CCW)

The UMI-7774/7772 Step (CW) and Dir (CCW) signals are used as command outputs to a stepper drive. Some stepper drives require clockwise direction (CW) and counter-clockwise direction (CCW) commands rather than Step and Dir commands. You can configure National Instruments motion controllers to provide either type of stepper commands. Both Step and Dir signals are pass-through signals.

## Fault

The Fault signal is an optically isolated digital input. If the Fault input signal is asserted, the **DISABLED LED** is lit and the Enable output signal is deactivated. You can wire the Fault input to either a current *sourcing* or *sinking* output from a drive or other device. Refer to Figures 3-5, 3-7, and 3-8 for examples of wiring the Fault input signal to sourcing and sinking output devices. In both cases, the isolated power ( $V_{iso}$ ) and isolated common ( $C_{iso}$ ) signals provided on the control connector are used to power the external devices.

Use a manual operator switch to handle disabling an axis. In this scenario, you wire the switch to the Fault input as shown in Figure 3-5.

You can configure the axis Fault input signals as active-low or active-high inputs using the switch for the axis labeled **FAULT**. The down position of the switch corresponds to active-low and the up position of the switch corresponds to active-high.

Refer to the [Voltage Considerations for the UMI-7774/7772](#) section for voltage information that applies to the Fault input signal.

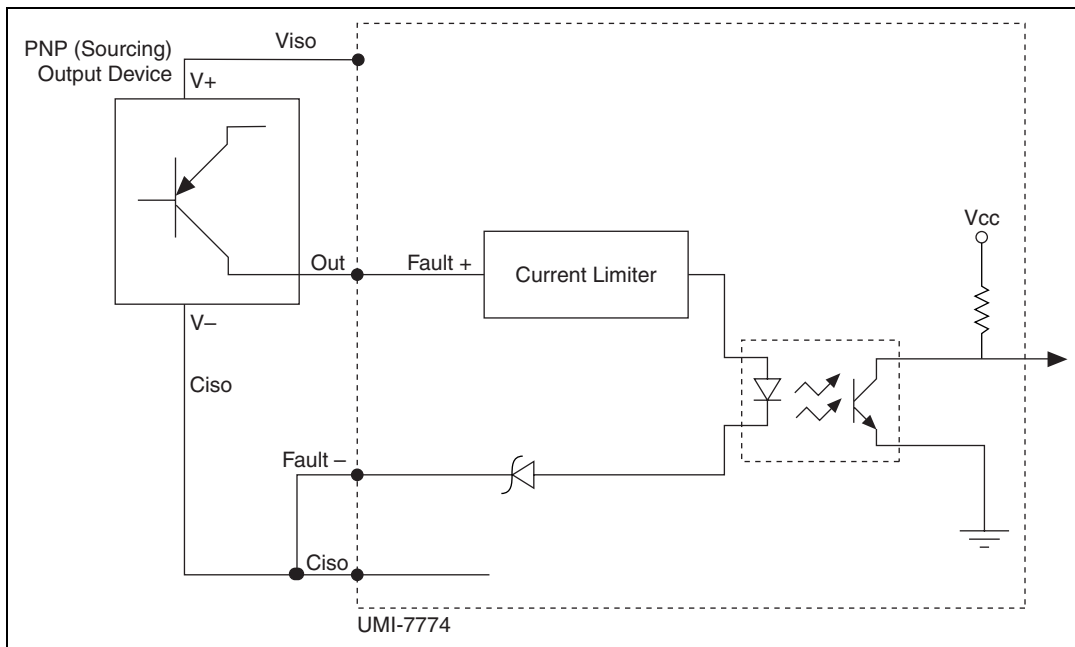

**Figure 3-5.** Example of Wiring a Sourcing Output Device to the Fault Input

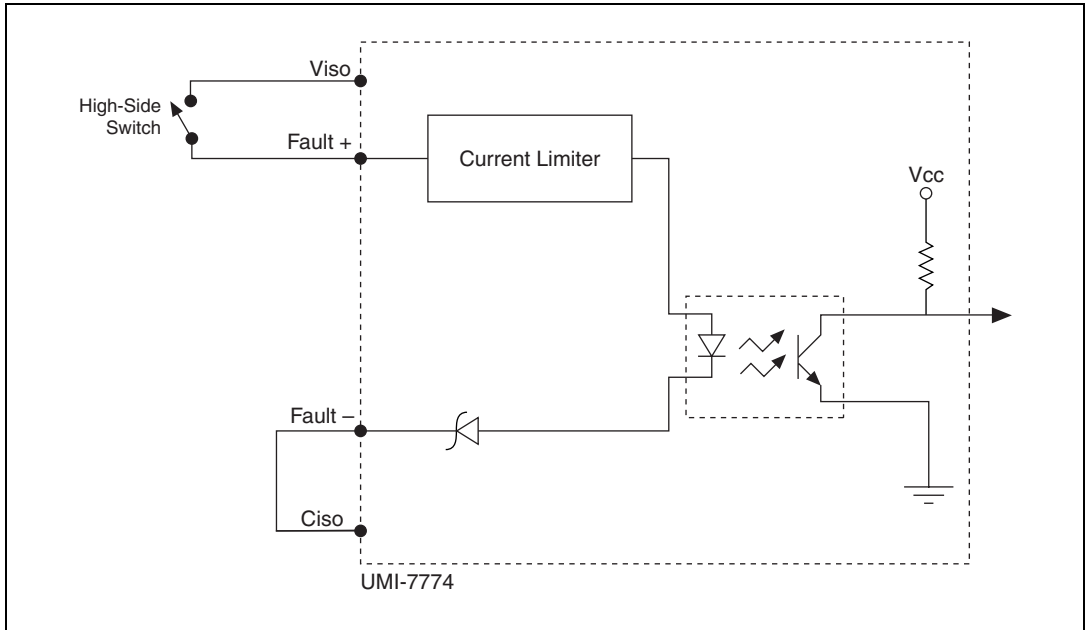

**Figure 3-6.** Example of Wiring a High-Side Switch to the UMI-7774/7772

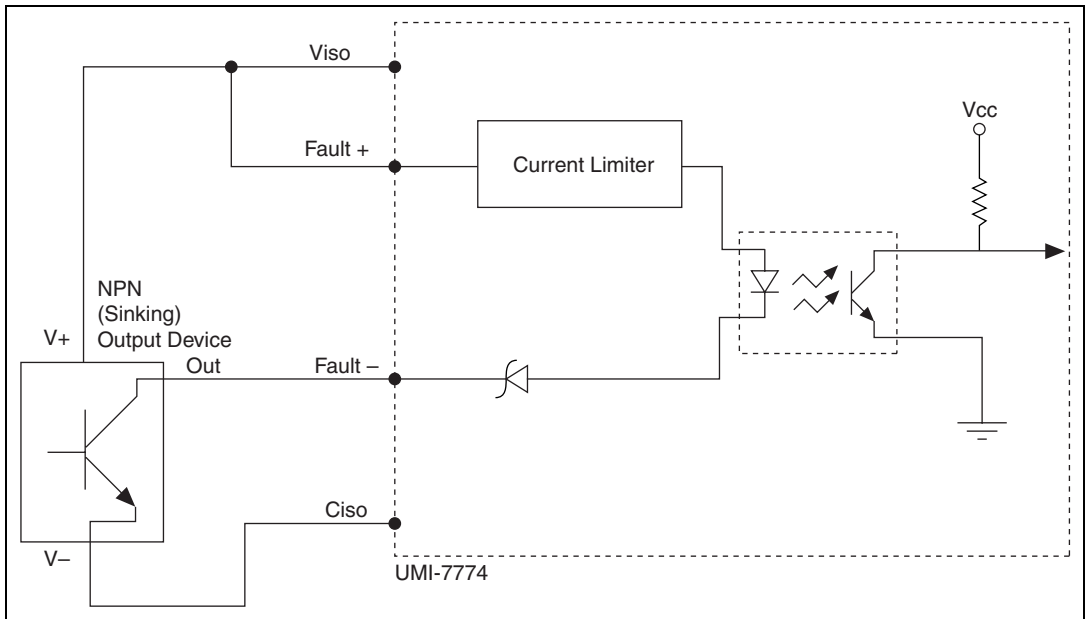

**Figure 3-7.** Example of Wiring a Sinking Output Device to the Fault Input

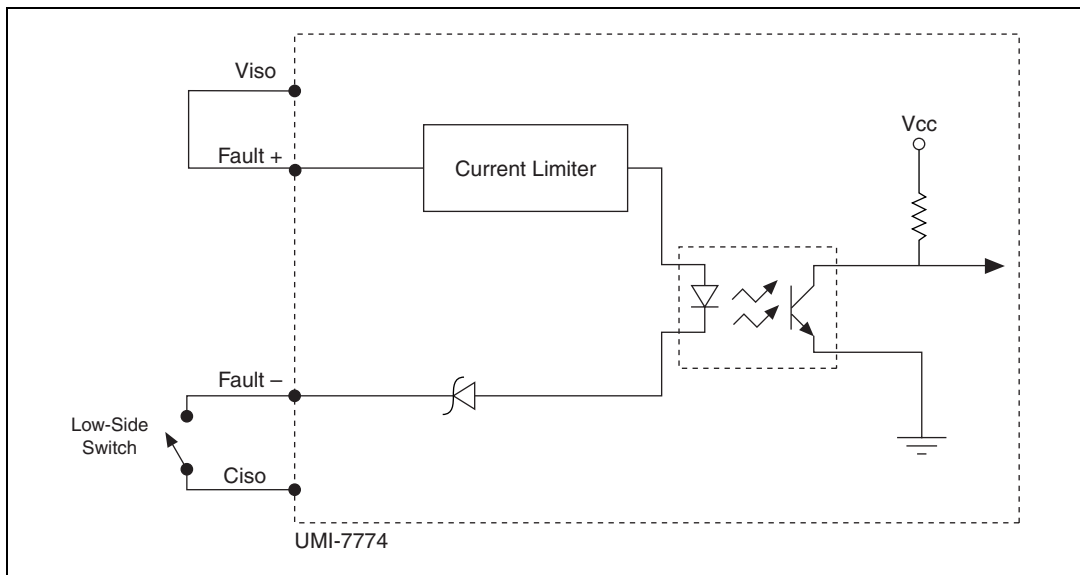

**Figure 3-8.** Example of Wiring a Low-Side Switch to the UMI-7774/7772

## Enable Output

The Enable output signal is an optically isolated digital output used to enable the drive for the axis. The Enable signal for the axis is deactivated when any of the following signals is asserted:

- Host Bus Interlock (global)
- Inhibit All (user-supplied and global)
- User-supplied external Fault input (per axis)
- Controller Inhibit Out (per axis)
- Controller Shutdown (if enabled on the controller)

Refer to the [Global Stop](#) section for information about the Inhibit All and Shutdown signals. The host bus interlock is a safety feature that is not user-configurable. It monitors the +5 V pin from the motion controller to verify that the motion controller is powered on and properly connected to the UMI-7774/7772.

You can configure the axis Enable output signal as active-low or active-high using the ENABLE switch. The down position for the switch corresponds to active-low and the up position for the switch corresponds to active-high. Refer to Figure 3-4 for the location of this switch. Refer to Figure 3-9 for a diagram that shows how to wire the Fault, Enable, and Global Stop signals.



**Note** You must configure the National Instruments motion controller Inhibit Out signals as active-low for proper operation of the inhibit logic on the UMI-7774/7772.

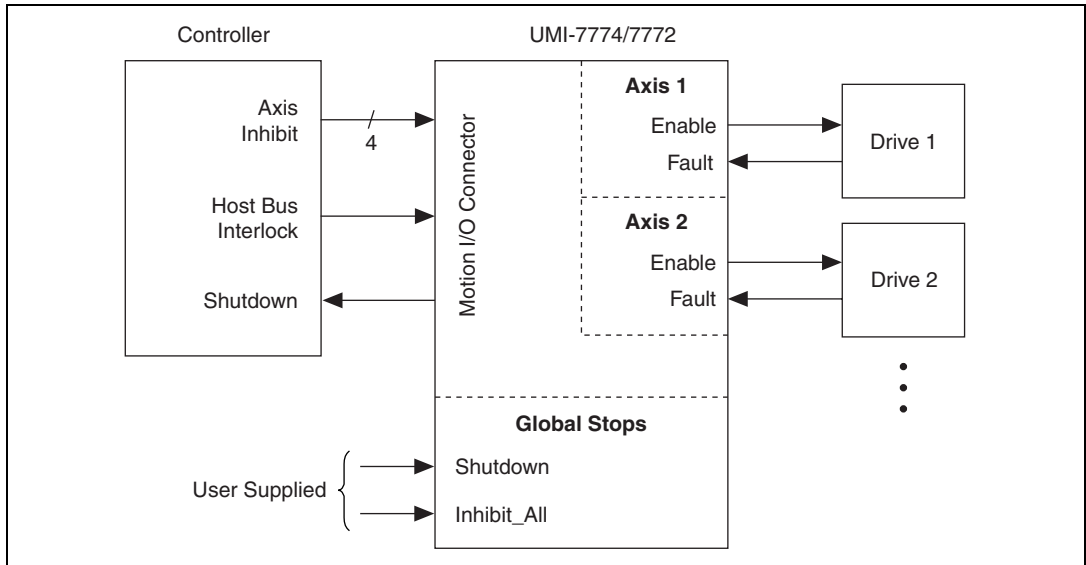

**Figure 3-9.** Fault, Enable, and Global Stop Wiring Diagram

The Enable output circuit provides a current source to an external device. The maximum output current is 100 mA. The output voltage is within 1.2 V of the voltage setting on the  $V_{iso}$  power supply. Refer to Figure 3-10 for an illustration of the Enable output interface circuit.



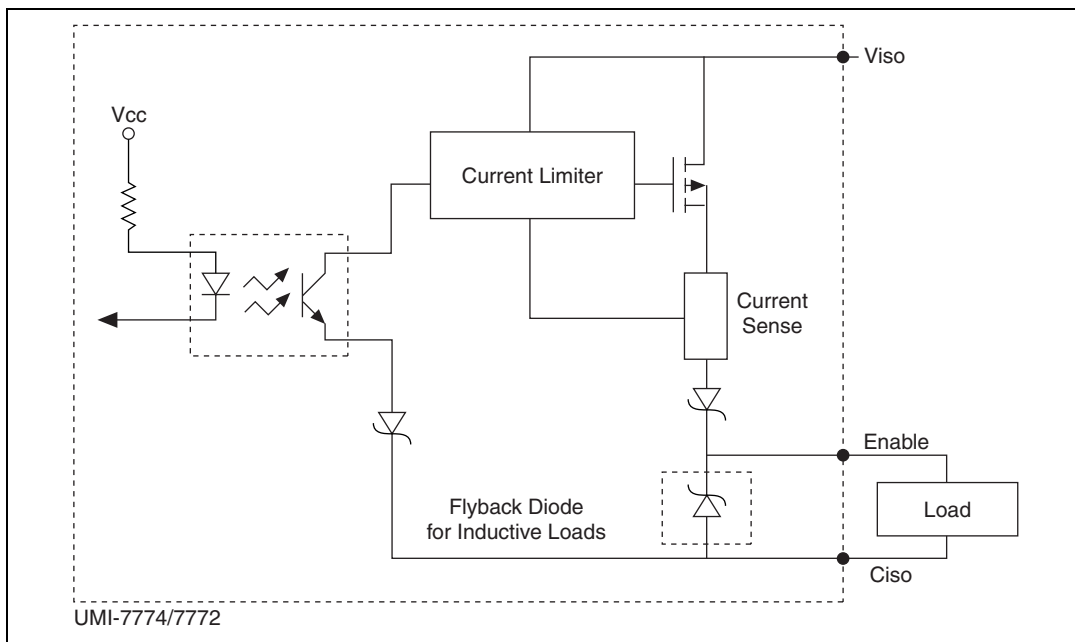

**Figure 3-10.** UMI-7774/7772 Enable Output Interface Circuit and Connection to an External Device

## Fault Input and Disabled Status Indicators

Each axis of the UMI-7774/7772 has the following two status LEDs: **DISABLED** and **FAULT**. If the Enable output signal is deactivated for any reason, the **DISABLED** LED illuminates. If the Fault input signal is also active, both the **FAULT** and the **DISABLED** LEDs for the axis illuminate. Refer to Figure 3-4 for the locations of these LEDs.

## Sinusoidal Commutation Configuration

The control connectors for axes 1 and 2 of the UMI-7774/7772 have additional analog output signal connections to accommodate brushless servo drives that do not provide onboard sinusoidal commutation. These signal connections are shown in Tables 3-3 and 3-4. For these types of drives, you must use a National Instruments motion controller that provides the sinusoidal commutation. The National Instruments motion controllers with this feature provide two analog output commands, with a phase difference of 120 degrees, for a single axis of motion. You can connect each UMI-7774/7772 to two brushless drives. For example, you can connect the axis 1 control connector to one drive using analog outputs 1 and 3, and connect the axis 2 control connector to another drive using

analog outputs 2 and 4. You can connect Hall effect sensors that are used for initializing the sinusoidal commutation to the Feedback Connector. Refer to Figure 3-11 for a diagram that demonstrates this configuration.

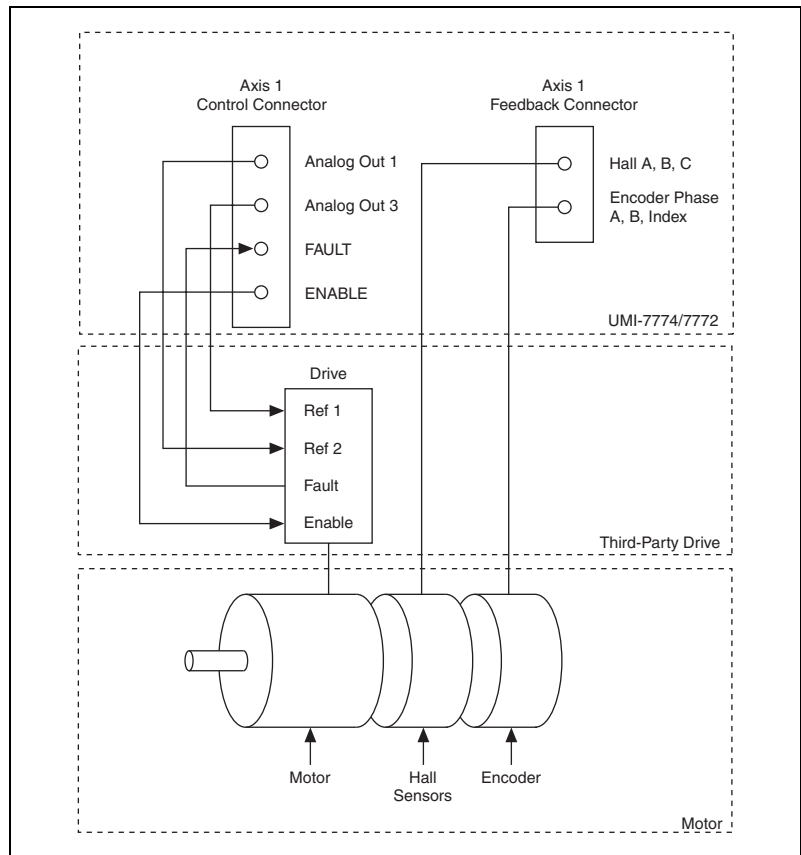

**Figure 3-11.** Sinusoidal Commutation Wiring Diagram



**Note** The Hall effect sensor connections are shown on Pins 5, 6, and 7 in Table 3-5.



**Note** You also can use drives with onboard sinusoidal commutation for brushless motors. These drives can be more expensive, but each drive requires only one analog output signal.

When you set up the UMI-7774/7772 for sinusoidal commutation, you connect the axis 1 feedback connector to the set of Hall effect sensors for one brushless motor and the axis 2 feedback connector to the set of Hall effect sensors for another brushless motor.

All of the Hall effect sensor signals are pass-through signals to the National Instruments motion controller general-purpose digital inputs.

**Table 3-3.** Control 1 Connector Pin Assignment for Sinusoidal Commutation

Pin	Signal	Optically Isolated
1	Analog Output 1	No
2	Analog Output 3	No
3	+ 5 V (Output)	No
4	Step (CW)	No
5	n.c.	No
6	Enable Output	Yes
7	Fault +	Yes
8	Iso Power (Output)	Yes
9	Analog Output Ground	No
10	Digital Ground	No
11	Digital Ground	No
12	Dir (CCW)	No
13	n.c.	No
14	Fault –	Yes
15	Iso Common	Yes

**Table 3-4.** Control 2 Connector Pin Assignment for Sinusoidal Commutation

Pin	Signal	Optically Isolated
1	Analog Output 2	No
2	Analog Output 4	No
3	+ 5 V (Output)	No
4	Step (CW)	No
5	n.c.	No

**Table 3-4.** Control 2 Connector Pin Assignment for Sinusoidal Commutation (Continued)

<b>Pin</b>	<b>Signal</b>	<b>Optically Isolated</b>
6	Enable Output	Yes
7	Fault +	Yes
8	Iso Power (Output)	Yes
9	Analog Output Ground	No
10	Digital Ground	No
11	Digital Ground	No
12	Dir (CCW)	No
13	n.c.	No
14	Fault –	Yes
15	Iso Common	Yes

## Feedback Connector for Each Axis

Each axis connected to the UMI-7774/7772 has a 25-pin D-Sub feedback connector to which you can wire incremental encoders, limits, and home sensors. The feedback connectors for axes 1 and 2 have additional connections for Hall effect sensors for brushless motors. Figure 3-4 shows the pin locations of the feedback connector for each axis. Table 3-5 shows the corresponding signals for each pin.

**Table 3-5.** Per Axis Feedback Connector Pin Assignment

<b>Pin</b>	<b>Signal</b>	<b>Optically Isolated</b>
1	Encoder Phase A	No
2	Encoder Phase B	No
3	Encoder Index	No
4	+ 5V (Output)	No
5	Hall Sensor A	No
6	Hall Sensor B	No
7	Hall Sensor C	No
8	+ 5V (Output)	No
9	n.c.	No
10	Forward Limit	Yes
11	Home Input	Yes
12	Reverse Limit	Yes
13	Iso Power (Output)	Yes
14	Encoder Phase A-	No
15	Encoder Phase B-	No
16	Encoder Index-	No
17	Digital Ground	No
18	Digital Ground	No
19	Digital Ground	No
20	Digital Ground	No
21	n.c.	No
22	Iso Common	Yes
23	Iso Common	Yes
24	Iso Common	Yes
25	Iso Common	Yes



**Note** The Hall sensors are available only on Feedback Connectors 1 and 2.

## Encoder

The UMI-7774/7772 works only with encoders that have differential line or complementary driver outputs. Refer to Figure 3-14 for an illustration of the encoder input interface circuit. The UMI-7774/7772 supports differential inputs for Phase A, Phase B, and Index signals.



**Note** The UMI-7774/7772 does *not* support single-ended encoders.

The interface circuit for the encoder inputs is shown in Figure 3-14. The differential encoder signals are converted to single-ended signals by a differential-to-single-ended converter on the UMI-7774/7772 and are then passed through to the National Instruments motion controller.

You can accommodate encoders with various phase relationships by swapping the signals and/or connecting them to the inverting inputs as required by the application. A +5V output, generated by the UMI-7774/7772 internal power supply, is also available on the connector for powering encoders. Figure 3-12 shows the default encoder phasing for National Instruments motion controllers. You can configure this phasing using Measurement and Automation Explorer (MAX) or NI-Motion driver software.

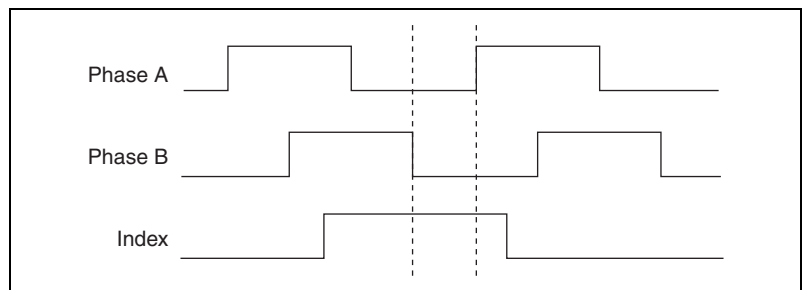

**Figure 3-12.** Encoder Signal Phasing, CW (Forward) Direction

Closed-loop servo applications require consistent directional polarity between the motor and encoder for correct operation. The National Instruments motion control standard directional polarity is as follows:

- Positive = forward = clockwise (CW) facing motor shaft
- Negative = reverse = counter-clockwise (CCW) facing motor shaft

When connecting the encoder wiring to the UMI-7774/7772, use shielded wire of at least 24 AWG. National Instruments recommends you use cables with twisted pairs and an overall shield for improved noise immunity signal integrity. Figure 3-13 shows twisted pairs in a shielded cable.



**Caution** Using an unshielded cable allows noise to corrupt the encoder signals, which could result in lost counts, reduced accuracy, and other erroneous encoder and controller operations.

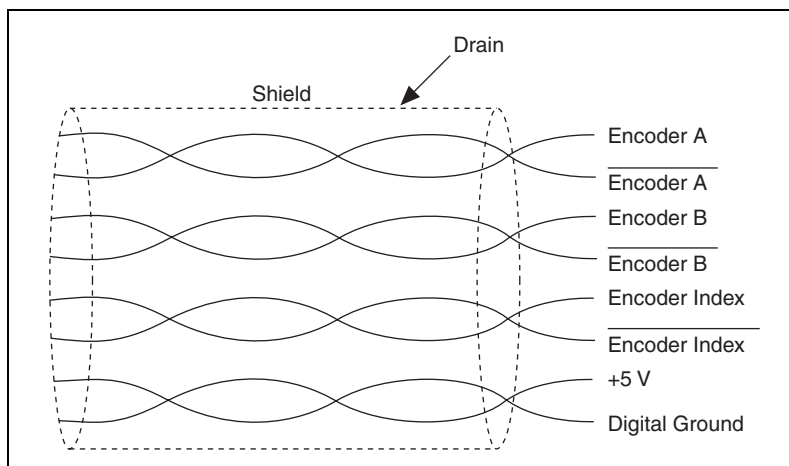

**Figure 3-13.** Shielded Twisted Pairs

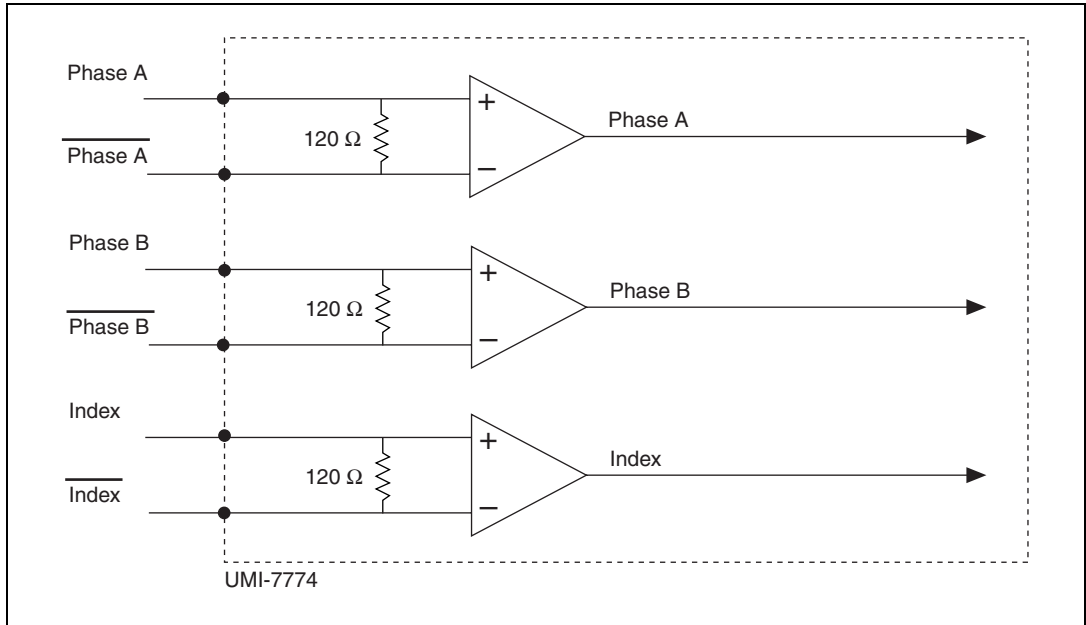

**Figure 3-14.** UMI-7774/7772 Encoder Input Interface Circuit

### Pass-Through Signaling on Encoders and Limits

Some drives have pass-through signaling on encoders and limits. If the drive has the pass-through feature, ensure that the drive does not filter the encoder or limit signals because this could reduce achievable closed-loop performance and stability for the system. If the drive does not have pass-through signaling for encoders and limits or if you choose not to use the pass-through signaling, you can connect the UMI-7774/7772 to the encoders and limits directly. If you are using Hall effect sensors for brushless motors and also are using a National Instruments motion controller with sinusoidal commutation, connect to these sensors either directly or through the drive.

### Limit and Home Inputs

The UMI-7774/7772 has connections available for forward limit, reverse limit, and home sensors or switches. The limit sensors or switches are typically located at physical ends of travel. The home sensor or switch can be located at any reference position within the range of travel.



The limits and home inputs are sinking inputs on the UMI-7774/7772 and are optically isolated. A sinking input is an input terminal that can sink by providing a path to a supply common or ground. You can wire this type of input to a *sourcing output* device. A sourcing output device can source current by providing a path to a supply source. PNP sensors are examples of sourcing output devices. The interface circuit is the same for the forward limits, reverse limits, and home inputs. As shown in Figure 3-15, you can wire a sourcing output device, such as a PNP sensor, to the limit or home inputs. You can use the isolated power ( $V_{iso}$ ) and isolated common ( $C_{iso}$ ) signals provided on the control connector to power the limit/home sensor.

Refer to the [Voltage Considerations for the UMI-7774/7772](#) section for voltage information that applies to the limit and home switches and sensors.

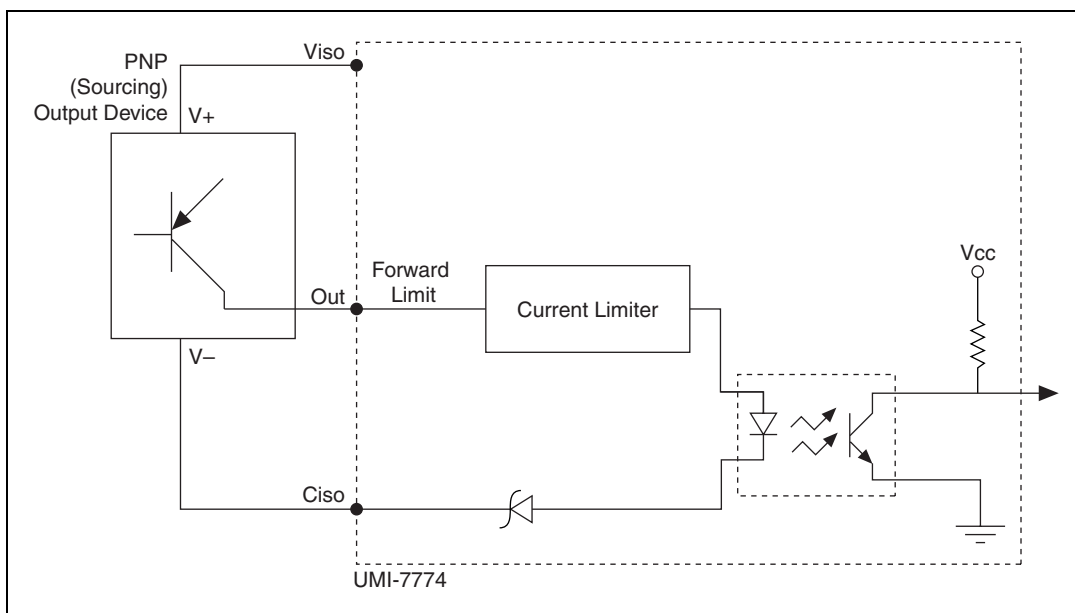

**Figure 3-15.** UMI-7774/7772 Forward Limit, Shutdown, and Trigger Input Interface Circuit and Connection to Sourcing Output Sensor

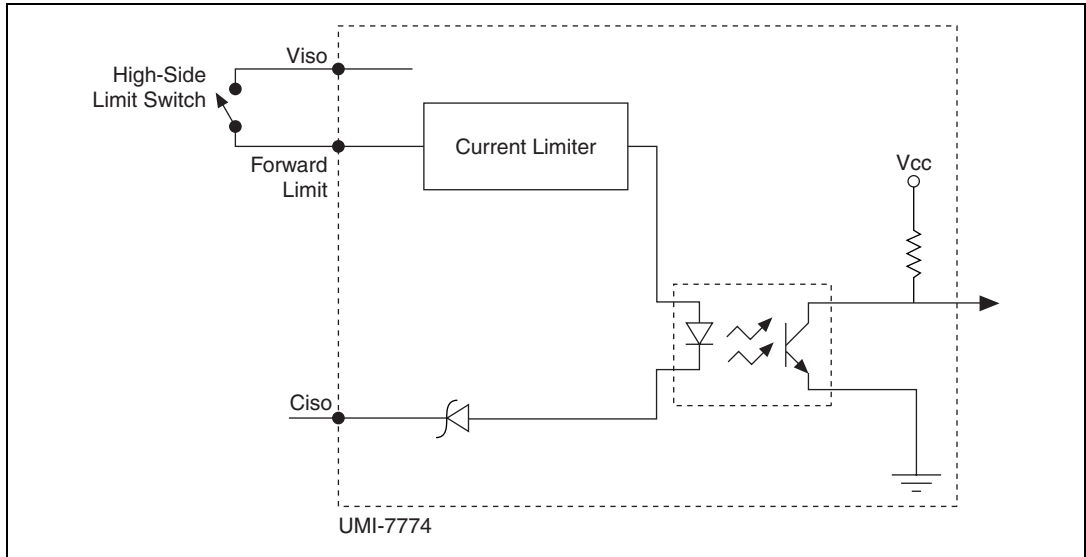

**Figure 3-16.** UMI-7774-7772 Forward Limit Interface Circuit and Connection to High-Side Limit Switch

For the end of travel limits to function correctly, the forward limit must be located at the forward or positive end of travel, and the reverse limit must be located at the negative end of travel.



**Caution** Failure to follow these guidelines may result in motion that stops at a limit, but then travels through it, potentially damaging the motion system. Miswired limits may prevent motion from occurring at all.

## Limit and Home Status Indicators

The UMI-7774/7772 has yellow status LEDs for the forward limit, reverse limit, and home input signals. Refer to Figure 3-4 for help locating these LEDs. You can configure the limit and home status LEDs as active-low or active-high using the switch for the axis labeled **LIMIT LED**. The down position of the switch corresponds to active-low and the up position for the switch corresponds to active-high. Refer to Figure 3-4 for the locations of these LEDs.



**Note** Configuring the limit and home status LEDs on the UMI-7774/7772 does not configure the limit and home inputs themselves as active-high or active-low. You must configure the limit and home inputs separately on the National Instruments motion controller using MAX or NI-Motion driver software.

The yellow status LEDs for the limits and home inputs illuminate when the inputs are active. Refer to Figure 3-4 for the locations of these indicators.

## Hall Effect Sensors for Sinusoidal Commutation Configuration

The feedback connectors for axes 1 and 2 of the UMI-7774/7772 have additional signal connections for digital Hall effect sensors to accommodate brushless servo drives without onboard sinusoidal commutation. For these types of drives, you must use a National Instruments motion controller that provides the sinusoidal commutation.

When you set up the UMI-7774/7772 for sinusoidal commutation, you connect the axis 1 feedback connector to the set of Hall effect sensors for one brushless motor and the axis 2 feedback connector to the set of Hall effect sensors for another brushless motor. When you use the feedback connectors for axes 1 and 2 in this manner, you do not need to use the feedback connectors for the other two axes on the UMI-7774.

All of the Hall effect sensor signals are pass-through signals to the National Instruments motion controller general-purpose digital inputs.

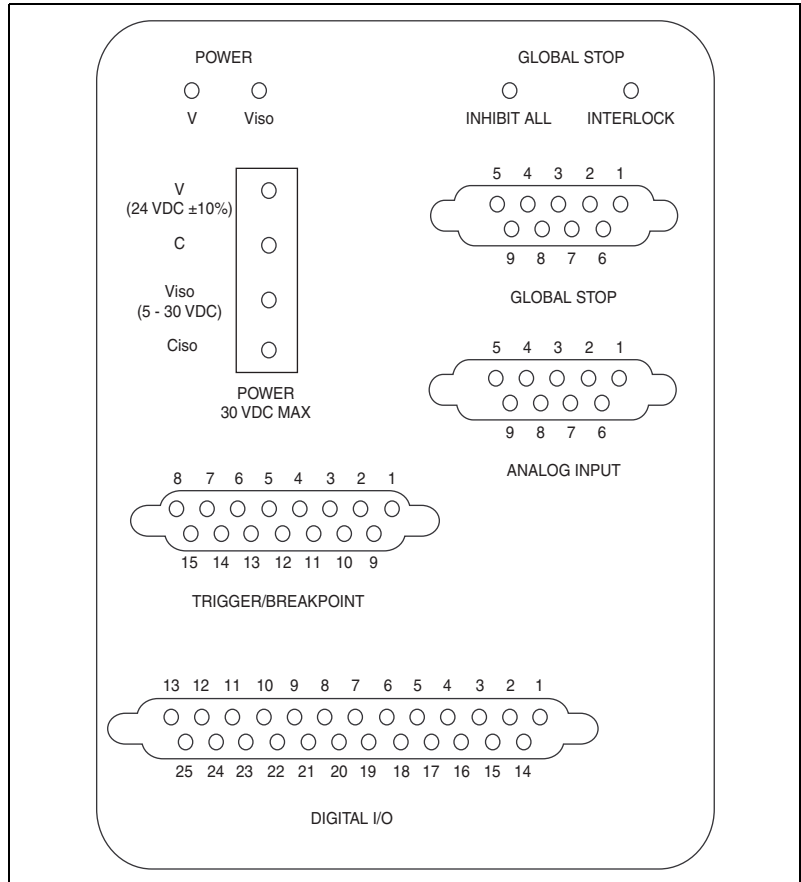

**Figure 3-17.** UMI-7774/7772 Pin Locations for Global Stop, Analog Input, Trigger/Breakpoint, and Digital I/O Connectors

## Global Stop

The UMI-7774/7772 has a single 9-pin D-Sub connector for global stop wiring. This connector includes the Inhibit All input and the Shutdown input signals. Both signals are optically isolated sinking inputs.

### Inhibit All

The Inhibit All signal acts as a global inhibit, and when asserted, activates the Enable outputs for all of the axes on the UMI-7774/7772.

## Shutdown

The Shutdown signal is passed through to the motion controller and is typically used to disable the controller. Refer to Figure 3-17 for the pin locations of the Global Stop connector and refer to Table 3-6 for the corresponding signals for each pin. Refer to Figure 3-1 to locate the Global Stop connector on the UMI-7774/7772.

**Table 3-6.** Global Stop Connector Pin Assignment

Pin	Signal	Optically Isolated
1	Shutdown	Yes
2	Inhibit All	Yes
3	n.c.	No
4	n.c.	No
5	Iso Power (Output)	Yes
6	Iso Common	Yes
7	Iso Common	Yes
8	Iso Common	Yes
9	Iso Common	Yes

Both the Shutdown and Inhibit All inputs are sinking inputs on the UMI-7774/7772 and are optically isolated. The Shutdown interface circuit is shown in Figure 3-15. The interface circuit is the same for the Inhibit All input. You can wire the Shutdown and Inhibit All inputs to a sourcing output device, such as a PNP sensor, as shown in Figure 3-15. You can use the isolated power ( $V_{iso}$ ) and isolated common ( $C_{iso}$ ) signals on the control connector to power the sensor.

Refer to the [Voltage Considerations for the UMI-7774/7772](#) section for voltage information that applies to the global stop wiring.

## Analog Input

The UMI-7774/7772 has a single 9-pin D-Sub connector that provides access to the four analog input channels on the motion controller. The analog inputs are pass-through signals on the UMI-7774/7772. Refer to Figure 2-1, [UMI-7774, Front View with Dimensions](#), to help you locate the analog input connector on the UMI-7774/7772. Figure 3-17 shows the pin

locations for the Analog Input connector and Table 3-7 shows the corresponding signals for each pin.

**Table 3-7.** Analog Input Connector Pin Assignment

Pin	Signal
1	Analog Input 1
2	Analog Input 2
3	Analog Input 3
4	Analog Input 4
5	Analog Reference (Output)
6	Analog Input Ground
7	Analog Input Ground
8	Analog Input Ground
9	Analog Input Ground



**Note** None of the analog inputs are optically isolated.

## Trigger/Breakpoint

The UMI-7774/7772 has a single 15-pin D-Sub connector you can use for trigger input and breakpoint output wiring. This connector provides access to four trigger inputs and four breakpoint outputs.

### Trigger

The UMI-7774/7772 provides optical isolation on the trigger inputs. You can use the isolated power output and isolated common on the connector to power on the field devices that provide the trigger signals. All of the trigger inputs on the UMI-7774/7772 are sinking inputs and are optically isolated. You can wire the trigger input to a sourcing output device such as a PNP sensor, as shown in Figure 3-18. You can use the isolated power ( $V_{iso}$ ) and isolated common ( $C_{iso}$ ) signals on the control connector to power the sensor. Refer to Figure 3-15 for an example of an input interface circuit.

## Breakpoint

The breakpoint outputs are pass-through signals on the UMI-7774/7772. The breakpoint connector includes both +5V output and digital ground.

**Table 3-8.** Trigger/Breakpoint Connector Pin Assignment

Pin	Signal	Optically Isolated
1	Breakpoint 1	No
2	Breakpoint 3	No
3	+5V (Output)	No
4	Digital Ground	No
5	Iso Common	Yes
6	Trigger 1	Yes
7	Trigger 3	Yes
8	Iso Power (Output)	Yes
9	Breakpoint 2	No
10	Breakpoint 4	No
11	Digital Ground	No
12	n.c.	No
13	Trigger 2	Yes
14	Trigger 4	Yes
15	Iso Common	Yes

Refer to Figure 2-1, *UMI-7774, Front View with Dimensions*, to locate the Trigger/Breakpoint connector on the UMI-7774/7772. Refer to Figure 3-17 for the pin locations of the trigger/breakpoint connector and to Table 3-8 for the corresponding signals for each pin. Refer to the appropriate National Instruments motion controller documentation for information about trigger inputs and breakpoint outputs.

Refer to the *Voltage Considerations for the UMI-7774/7772* section for voltage information that applies to the trigger input and breakpoint output wiring.

## General-Purpose Digital I/O

The UMI-7774/7772 routes 16 of the general-purpose digital I/O lines of the National Instruments motion controller to a single 25-pin D-Sub connector. All 16 digital I/O signals are optically isolated on the UMI-7774/7772. These signals are configurable as inputs and/or outputs on the National Instruments motion controller. Use MAX or NI-Motion software to configure the bits on port 1 as inputs and the bits on port 2 as outputs.

The 8 bits from the first port on the motion controller (Port 1: bits 0–7) become sinking inputs on the UMI-7774/7772, and the 8 bits from the second port of the motion controller (Port 2: bits 0–7) become sourcing outputs on the UMI-7774/7772. Refer to Figure 3-17 for the pin locations of the Digital I/O connector and Table 3-9 for the corresponding signals for each pin. Refer to Figure 3-1 to locate the Digital I/O connector on the UMI-7774/7772.

**Table 3-9.** Digital I/O Connector Pin Assignment

Pin	Signal	Optically Isolated
1	Digital Input 0	Yes
2	Digital Input 2	Yes
3	Digital Input 4	Yes
4	Digital Input 6	Yes
5	Iso Power (Output)	Yes
6	Iso Power (Output)	Yes
7	n.c.	No
8	Digital Output 0	Yes
9	Digital Output 2	Yes
10	Digital Output 4	Yes
11	Digital Output 6	Yes
12	Iso Power (Output)	Yes
13	Iso Power (Output)	Yes
14	Digital Input 1	Yes
15	Digital Input 3	Yes



**Table 3-9.** Digital I/O Connector Pin Assignment (Continued)

Pin	Signal	Optically Isolated
16	Digital Input 5	Yes
17	Digital Input 7	Yes
18	Iso Common	Yes
19	Iso Common	Yes
20	Iso Common	Yes
21	Digital Output 1	Yes
22	Digital Output 3	Yes
23	Digital Output 5	Yes
24	Digital Output 7	Yes
25	Iso Common	Yes

You can wire a Digital Input to a sourcing output device, such as a PNP sensor, as shown in Figure 3-18. You can use the isolated power ( $V_{iso}$ ) and isolated common ( $C_{iso}$ ) signals on the control connector to power on the sensor. Refer to Figure 3-15 for an example of an input circuit.

The Digital Output circuit sources current to external loads. The maximum output current is 100 mA. The output voltage is within 1.2 V of the voltage setting on the  $V_{iso}$  power supply. Refer to Figure 3-18 for an illustration of the Digital Output interface circuit.

Refer to the [Voltage Considerations for the UMI-7774/7772](#) section for voltage information that applies to the general-purpose digital I/O lines.

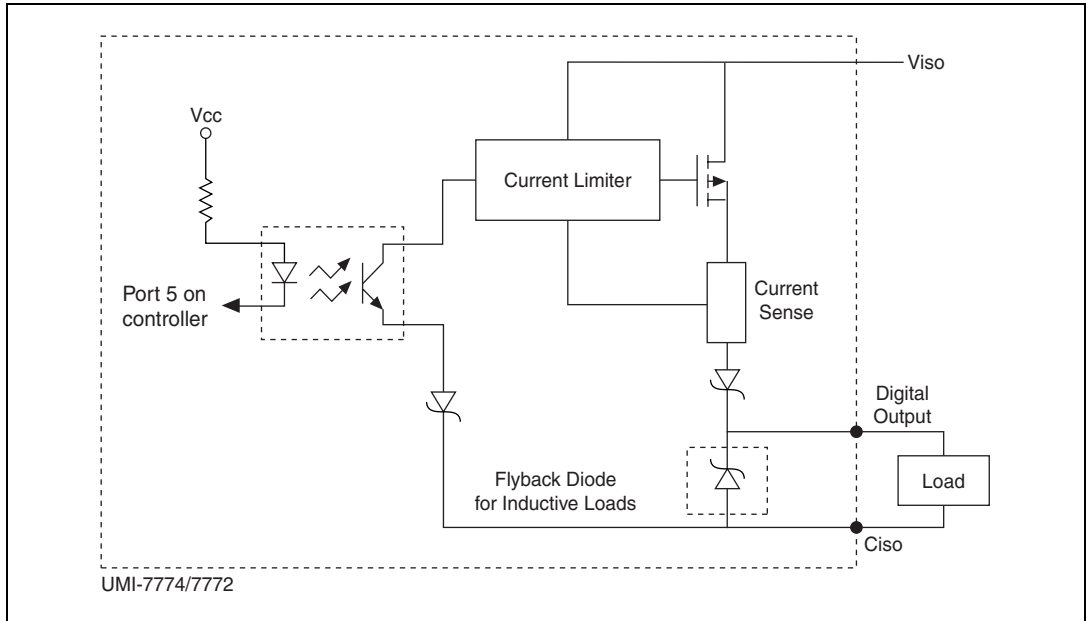

**Figure 3-18.** UMI-7774/7772 General-Purpose Digital Output Interface Circuit and Connection to an External Load

## Connecting Switches to UMI-7774/7772 Sinking Inputs

Figure 3-16 shows an example of connecting a physical switch to a general purpose Digital Input on the UMI-7774/7772. You can make the same type of connection for the following UMI-7774/7772 sinking inputs:

- Limits and Home
- Triggers
- Inhibit All
- Shutdown
- General-Purpose Digital Input

Refer to Figures 3-8 and 3-16 for examples of wiring a switch to the UMI-7774/7772 general-purpose inputs.

## Inductive Loads Connected to UMI-7774/7772

When an inductive load, such as a relay or solenoid, is connected to an output, a large counter-electromotive force may occur at switching time because of the energy stored in the inductive load. This flyback voltage can damage the outputs and the power supply. You must limit flyback voltages at the inductive load by installing a flyback diode across the load.

Typically, you mount the flyback diode as close to the load as possible. Use this protection method if you connect any of the Enable outputs or general-purpose digital outputs on the UMI-7774/7772 to an inductive load. Refer to Figure 3-19 for an illustration of the interface circuit for a general-purpose digital output that is connected to an external device with a flyback diode.



**Note** If the load current exceeds the over current trip point minimum of 100 mA, the output shuts off. To re-enable the input and power on the output, disconnect the load.

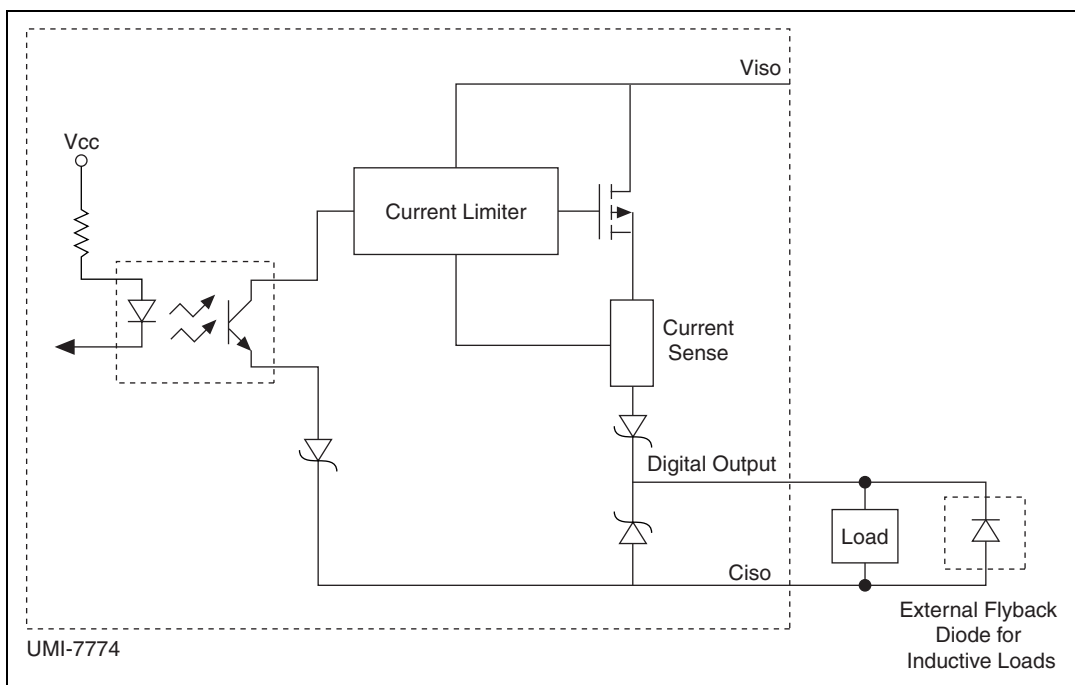

**Figure 3-19.** Use of External Flyback Diode for Inductive Loads

## Servo Drive Modes

---

National Instruments recommends that when you use the UMI-7774/7772 with a servo motor drive, you use the torque (current) mode option on the drive instead of the velocity mode to simplify the system setup and tuning. In torque mode, only the current loop is closed on the drive. Both the position and velocity loops are closed on the motion controller using encoder feedback.

When you use torque mode, you can set all of the control gains with the National Instruments motion controller software. Using torque mode on the drive also reduces noise and enables you to achieve high position repeatability in the motion system.

Refer to the documentation included with the drive system for more information about the drive.

## National Instruments Motion Advisors

---

You can use National Instruments Motion Advisors to find National Instruments and third-party drives that will work for your application. Visit [ni.com/motion/advisors](http://ni.com/motion/advisors) to access the National Instruments Motion Advisors. The Drive Advisor shows compatible drives that work with a wide variety of motors and actuators. The Stage Advisor shows specific motorized stage and drive combinations.

---

## Specifications

The following specifications apply only to the UMI-7774/7772. Consider the specifications for the National Instruments motion controller you are using to obtain a complete system specification for the UMI-7774/7772. Refer to the controller specifications to determine overall system specifications. Some signals have compatibility defined as signal pass-through. This means the UMI-7774/7772 may have passive filtering on these signals, but the passive filtering does not affect the voltage range or current handling capability. Consult the motion controller specifications to determine the allowable voltage range and logic level compatibility of the signal.

The following specifications are typical for temperatures from 0 to 55 °C unless otherwise noted.

### Encoder Interface

Inputs.....	Quadrature, incremental
Differential input threshold.....	$\pm 0.3$ V (typical), RS-422 compatible
Termination.....	120 $\Omega$
Input voltage range.....	0 to 5.5 VDC
Max quadrature frequency.....	20 MHz

### Limit and Home Switch, Inhibit, Inhibit All/Shutdown, and General Purpose Digital Inputs

Type.....	Optically isolated, current sinking
Input voltage range.....	0 to 30 V
Input ON voltage.....	3.5 to 30 V
Input OFF voltage.....	0 to 2 V
Turn on current.....	14 mA maximum, current limited 3 mA minimum, current limited



## General Purpose Digital Outputs

Type .....	Optically isolated, current sourcing
Number of outputs .....	8
Output voltage range .....	5 to 30 V
Output current .....	100 mA
Maximum pulse rate.....	10 KHz
Minimum pulse generated.....	100 $\mu$ s
Maximum on-state voltage drop .....	1.2 V at 100 mA
Reverse polarity protection .....	Yes, -30 V
Short circuit and overload protection.....	Yes

## Step/Direction/Breakpoint Outputs

Type .....	TTL
Output voltage range	
$V_{oh}$ .....	+2.4 V (min) at 16 mA
$V_{ol}$ .....	+0.4 V (max) at 16 mA
Maximum pulse rate.....	8 MHz
Minimum pulse generated.....	125 ns
Short circuit protection.....	None

## Analog Inputs

Compatibility .....	Signal pass-through
---------------------	---------------------

## Analog Outputs

Compatibility .....	Signal pass-through
---------------------	---------------------

## Host Bus Voltage Interlock

Voltage .....	5 VDC $\pm$ 5%
---------------	----------------

## Power Characteristics

Input voltage range .....	24 V $\pm$ 10%, .20 Amps
Iso power source .....	5 to 30 VDC, 1.75 Amps

## Environmental Conditions

Operating temperature .....	0° to 55° C
Storage temperature .....	-30° to 80° C
Humidity .....	10 to 90% RH, noncondensing
Maximum altitude.....	2,000 meters
Pollution Degree .....	2

## Shock and Vibration

Operating shock (IEC 60068-2-27)	
Panel mount.....	30 g, 11 ms half sine, 3 shocks
Operating vibration, random (IEC 60068-2-34)	
DIN rail.....	1 g RMS, 10–500 Hz at .002 g <sup>2</sup> /Hz
Panel mount.....	5 g RMS, 10–500 Hz at .01 g <sup>2</sup> /Hz
Operating vibration, sinusoidal (IEC 60068-2-6)	
Panel mount.....	5 g, 10–500 Hz

## Physical Characteristics

Weight .....	2.5 lbs
Dimensions	
Length.....	259.08 cm (10.200 in.)
Width .....	126.93 cm (5.00 in.)
Depth .....	22.01 cm (0.867 in.)



## Safety

The UMI-7774/7772 is designed to meet the requirements of the following standards of safety:

- IEC 61010-1, EN 61010-1
- UL 3121, UL 61010C-1
- CAN/CSA C22.2 No. 1010.1



**Note** For UL and other safety certifications, refer to the product label or to [ni.com](http://ni.com).

## Electromagnetic Compatibility

Emissions ..... EN 55011 Class A at 10 m  
FCC Part 15A above 1 GHz

Immunity ..... EN 61326:1997 + A1:2001,  
Table 1

CE, C-Tick and FCC Part 15 (Class A) Compliant



**Note** For EMC compliance, you *must* operate this device with shielded cabling.

## CE Compliance

This product meets the essential requirements of applicable European Directives, as follows:

Low-Voltage Directive (safety) ..... 73/23/EEC

Electromagnetic Compatibility  
Directive (EMC) ..... 89/336/EEC



**Note** Refer to the Declaration of Conformity (DoC) for this product for any additional regulatory compliance information at [ni.com](http://ni.com). You can find the DoC using the search.

---

# Technical Support and Professional Services

Visit the following sections of the National Instruments Web site at [ni.com](http://ni.com) for technical support and professional services:

- **Support**—Online technical support resources include the following:
- **Training**—Visit [ni.com/training](http://ni.com/training) for self-paced tutorials, videos, and interactive CDs. You also can register for instructor-led, hands-on courses at locations around the world.
- **System Integration**—If you have time constraints, limited in-house technical resources, or other project challenges, NI Alliance Program members can help. To learn more, call your local NI office or visit [ni.com/alliance](http://ni.com/alliance).
- **Declaration of Conformity (DoC)**—A DoC is our claim of compliance with the Council of the European Communities using the manufacturer's declaration of conformity. This system affords the user protection for electronic compatibility (EMC) and product safety. You can obtain the DoC for your product by visiting [ni.com/hardref.nsf](http://ni.com/hardref.nsf).
- **Calibration Certificate**—If your product supports calibration, you can obtain the calibration certificate for your product at [ni.com/calibration](http://ni.com/calibration).

If you searched [ni.com](http://ni.com) and could not find the answers you need, contact your local office or NI corporate headquarters. Phone numbers for our worldwide offices are listed at the front of this manual. You also can visit the Worldwide Offices section of [ni.com/niglobal](http://ni.com/niglobal) to access the branch office Web sites, which provide up-to-date contact information, support phone numbers, email addresses, and current events.

# Index

---

## A

analog input connector, 3-24

## B

braided shield, cables, 2-2

breakpoint output, 3-25

brushless motors, 3-22

## C

cables, braided shield, 2-2

calibration certificate, B-2

connecting

    general purpose digital I/O, 3-2

    NI motion controllers, 3-2

    physical switches to general purpose  
    digital I/O, 3-29

connectors

    D-Sub control, 3-5

    power input terminal block, 3-5

    power status indicators, 3-5

contacting National Instruments, B-2

conventions used in the manual, *vii*

customer

    education, B-1

    professional services, B-1

    technical support, B-1

## D

Declaration of Conformity, B-1

diagnostic resources, B-1

DIN rail, mounting, 2-7

DISABLED LED, 3-12

documentation

    conventions used in manual, *vii*

    online library, B-1

    related documentation, *vii*

drivers

    instrument, B-1

    software, B-1

D-Sub connectors

    Fault Input, 3-8

    Fault Output, 3-10

    feedback, 3-15

    metallic shielding, 2-2

D-Sub control connectors, 3-5

D-Sub controls

    analog output, 3-7

    Step (CW) and Dir (CCW), 3-7

## E

effects, low-level signals, 2-2

encoders, 3-17, 3-19

example code, B-1

## F

FAULT LED, 3-12

flyback voltage, 3-30

frequently asked questions, B-1

## G

general purpose digital I/O, 3-27

global stop connectors, 3-23

## H

Hall effect sensors, 3-22  
help  
    professional services, B-1  
    technical support, B-1  
home inputs, 3-19  
home status indicators, 3-21

## I

Inhibit All input, 3-24  
installation, 2-1  
installation category descriptions, 2-4  
instrument drivers, B-1

## K

KnowledgeBase, B-1

## L

limit inputs, 3-19  
limit status indicators, 3-21  
low-level signals, effects, 2-2

## M

metallic shielding, D-Sub connectors, 2-2  
mounting, 2-6  
    DIN rail, 2-7  
    panel, 2-8  
    rack, 2-11

## N

National Instruments  
    calibration certificate, B-2  
    customer education, B-1  
    Declaration of Conformity, B-1  
    professional services, B-1  
    system integration services, B-1

    technical support, B-1  
    worldwide offices, B-2

National Instruments Motion Advisors, 3-31  
noise considerations, 2-2

## O

online technical support, B-1  
optional equipment, 2-2

## P

panel-mounting, 2-8  
pass-through signaling, 3-19  
phone technical support, B-2  
power input terminal block, 3-5  
power status indicators, 3-5  
professional services, B-1  
programming examples, B-1

## R

related documentation, *vii*  
required materials, 2-1

## S

safety guidelines, 2-2  
safety information, 2-3  
servo motor drives, 3-31  
Shutdown input, 3-24  
sinusoidal commutation, 3-12  
software drivers, B-1  
status indicators, 3-12  
support, technical, B-1  
system integration services, B-1

## **T**

- technical support, B-1
- telephone technical support, B-2
- training, customer, B-1
- trigger input, 3-25
- troubleshooting resources, B-1
- twisted pair cable, using, 2-2

## **U**

- UMI-7774/7772
  - features, 1-2
  - overview, 1-1
- unpacking, 2-5
- using twisted pair cable, 2-2

## **W**

- Web
  - professional services, B-1
  - technical support, B-1
- worldwide technical support, B-2